



POWERFUL TOOLS

PRODUCT CATALOGUE

DISCOVER POWER ON WWW.KEIL.EU

CONTENT

WWW.KEIL.EU



HAMMER DRILL BITS

Page 9



CHISELS

Page 39



**STONE AND
SPECIAL DRILL BITS**

Page 45



METAL DRILL BITS

Page 73



WOOD DRILL BITS

Page 116

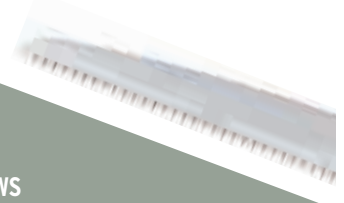

SAWS

Page 130

ASSORTMENTS

Page 137

MODULES

Page 155

INFO

Page 167

KEIL – POWERFUL TOOLS FOR SMART PROFESSIONALS

Welcome to the Keil catalogue! Powerful products for smart professionals. We seek to inspire and further expand our success with this new motto and a dynamic, modern brand image. We are strong, innovative and unique. This applies in particular to our product range, which impressively demonstrates our expertise from over 50 years as a manufacturer of quality tools. This catalogue shows the current Keil range including our product innovations and a wealth of valuable information about drilling.

In addition to our top-quality professional tools, we are establishing new, state-of-the-art services from which you and your customers will benefit. On the digital level, for example, we are proud to present the new Keil website. It stands out with its fresh design and offers valuable content such as the newly developed product advisor and our product videos. In the analogue sector we support you with our product presentation systems at the point of sale and secondary displays. Based on the current service offerings, we will gradually expand our support for you in the future.

The sum total of great quality products and outstanding service is the basis for our new brand slogan: Keil - Powerful Tools For Smart Professionals. Take advantage of this offer and let us work together to continue building on this success.

With kind regards



Dr. Robert Untiedt
Managing director



Jörg Frommeyer
Managing director

QUALITY



IN ANY CASE SAFETY IS DEMANDED!

Among others you can identify quality drilling tools by the quality mark of the independent 'PGM Masonry Drill Bit Certification Board' (PGM). Keil is a member of the founding board of the PGM (in 1978) and is authorized to use this mark. This quality mark guarantees the conformity of our drill bits with the requirements of the German Institute for Structural Engineering (DIBt) concerning drilling holes for anchors and plugs to be fixed in concrete and brick work with general building supervision admission or a European Technical Assessment (ETA). Violation by non-qualified manufacturers is legally prosecuted.



ADVANTAGES AND GUARANTEE

- Protect yourself against possible problems and claim for compensation which could result from the product liability law. In the event of a claim also the distributor could be held responsible, if the manufacturer or importer of a masonry drill bit without PGM-mark cannot be identified.
- Drill bit tolerances are balanced to the requirements of modern high performance plugs with European or national allowances and guarantee appropriate installation and anchor fixing of the plugs.
- These criteria are controlled constantly, therefore, they offer the distributor and the end user safety and confidence in the tool.

FOR FURTHER INFORMATION PLEASE VISIT WWW.PGM-ONLINE.DE



WHAT DOES THE PGM MARK STAND FOR?

- Selected qualified manufactures
- Production and quality assurance state-of-the-art supervised by PGM
- Clear marking instructions
- Strict tolerance limits for the diameter, the symmetry of the carbide tip and the out-of-true variation



THE NEXMART SPECIALISED TRADE PLATFORM

You have the possibility to purchase Keil quality drilling tools via Europe's leading business platform. Permanently updated articles of the entire Keil assortment are available 24 hours a day on nexmart.com and can be ordered online. nexmart is the independent specialized trade platform which is run and refined mutually by industry and trade. Realising economical advantages for all members is the most important target of nexmart. Using nexmart can reduce costs of processes along the entire value added chain. Accelerate, simplify and improve your ordering processes considerably - Keil and nexmart make it possible!

FOR FURTHER INFORMATION PLEASE VISIT WWW.NEXMART.COM



DIN EN ISO 9001

In addition to perfected production processes, quality assurance is of great importance. Inspection of incoming materials, intermediate checks, final checks and regular drilling and testing under extreme conditions provide new knowledge resulting in assurance and improvement of procedure as well as materials.

SERVICE-ORIENTED: THE NEW KEIL WEBSITE

Keil stands for powerful tools - and for state-of-the-art services, with which we sustainably support specialist retailers. As part of our brand relaunch, we have also completely revised the Keil website www.keil.eu

Our new website combines powerful design with a well-structured user interface and a range of services which are valuable for both retailers and end users. They include the newly developed product consultant, a detailed product overview, informative product videos and the Keil dealer area.

See for yourself and use our website for your business success.



FOR USE IN



	DESCRIPTION	PAGE	NORM	ARTICLE GROUP
HAMMER DRILL BITS	SDS-plus TURBOHEAD Xpro RS	12-13		251
	SDS-plus Power-4CE	14-15		267
	SDS-plus W2 TURBOKEIL X-shape	16		252
	SDS-plus M55 TURBOKEIL	17-20		253
	SDS-plus hammer drill bits KEILRAPID	22		256
	SDS-max W2 TURBOHEAD XPro / TURBOKEIL X-shape	23-26		270
	SDS-max TURBOCLEAN extraction drill bit	27		273
	SDS-plus TURBOCLEAN extraction drill bit	28		272
	SDS-max concrete milling cutter	29		269
	Break-through core drill bit	31		259
	Hammer hollow core	32-33		259
	Adapters with RATIO head	34		259
	Adapters for SDS-plus	36		265
	SDS-plus locating shank for chucks	37		264
CHISELS	Chisel RS self-sharpening	41		500 501
	Point chisel	42		502-509
	Flat chisel	42		502-509
	Spade chisel	43		502-509
	Hollow chisel	43		502 503
	Chisel with channel and glides	44		502 503
Tile chisel	44		502 503	
STONE AND SPECIAL DRILL BITS	Universal drill bit GOLDCRAFT	48-49	8039	119 219
	SDS-plus M55 universal drill bit GOLDCRAFT	50	8039	119
	Hard stone drill bit HARDETEC	51		168
	Tile/brick drill bit KERAMIK	52	8039	151
	Diamond core allround	53		786
	Tile drill bit KERAMIK diamond - dry drill	54-55		774
	Tile drill bit KERAMIK diamond - dry drill M14	54-55		788
	Glass drill bit	56		130
	Glass drill bit KEILBIT	57		131
	Universal drill bit KEILBIT	58	8039	166
	Concrete drill bit M55 TURBOHEAD Xpro	59	8039	238
	Concrete drill bit M55 TURBOKEIL	60	8039	258
	Granite drill bit PRIMUS	61	8039	150 200 400 600
	Percussion drill bit KEILER	62-63		190 200
	Masonry drill bit OPAL	64		190 290
	Universal hollow core	65		715
	Universal hollow core M16 GOLDCRAFT	66		719
	Centre drill bit GOLDCRAFT for locating shank M16	67		719
	Hollow core M16 complete	68		711
	Hollow core M16	69		710
	Locating shank M16 hexagon	70		712
	Locating shank M16 SDS-plus	71		713
	Centre drill bit for locating shank M16	71		715
Locating shank M16 SDS-PLUS complete	72		714	
Quick bit holder for bits and KEILBIT	72		800	
HSS DRILL BITS	HSS-E DIN 338 cobalt	76-79	338	307
	HSS TIN DIN 338 steel drill bit	80-81	338	311
	HSS DIN 338, ground, split point	82-85	338	302
	HSS DIN 338, standard	86-90	338	300
	HSS DIN 338, standard, shank reduced	91		300
	HSS DIN 340, ground, split point, long	92	340	340
	HSS DIN 1869, ground, extra long	93	1869	342
	HSS hollow section drill bit / Facade drill bit	94		344
	HSS DIN 345 morse taper	95-96	345	345
	HSS DIN 1897 pilot drill bit, ground, split point, extra short	97	1897	303
	HSS DIN 8037 carbide tipped	98	8037	310
	HSS-G SPEEDER DIN 338 RN metal drill bit	99	338	312
	HSS Double end drill bit, ground, split point	100		304
	HSS Drill bit KEILBIT, ground	101		315
	HSS combination tool KEILBIT	102		317
	HSS countersink KEILBIT	103	335 C	329
	HSS countersink 90° DIN 335 C	104	335 C	327
	HSS deburring countersink	105		328
	HSS tube and sheet drill bit	106		326
	HSS step drill	107		325
Scriber	108		140	
HSS hole saw bi-metal	109-112		320	
WOOD DRILL BITS	Wood twist drill bit	121-122	7487	180 280
	HSS Wood twist drill bit	123		186
	Wood twist drill bit KEILBIT	124		187
	Auger drill bit lewis shape	125		181
	Auger drill bit lewis shape with SDS-plus shaft	126		182
	Machine forstner bit	127	7483	183
	Flat bit KEILBIT	128		185
	Extension for flat bit KEILBIT	129		185
	Drill bit for timbering, round shank	130		350
	SDS-plus drill bit for timbering	131		355

FIND THE RIGHT TOOL EASILY:

THE NEW KEIL PRODUCT CONSULTANT ON WWW.KEIL.EU

STEP 1: Activities / Product sector



STEP 2: Select material group



STEP 3: Refine material



STEP 4: Area of application



STEP 5: Available shanks / Machines



SCAN QR-CODE AND
FIND THE RIGHT TOOL

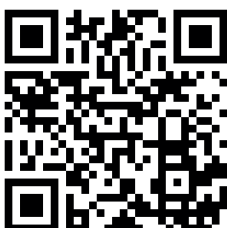

DISCOVER THE PRODUCT CONSULTANT: WWW.KEIL.EU

HAMMER DRILL BITS



251 SDS-plus TURBOHEAD XPRO RS	12-13
267 SDS-plus Power 4-CE	14-15
252 SDS-plus W2 TURBOKEIL X-shape	16
253 SDS-plus MS5 TURBOKEIL	17-20
256 SDS-plus hammer drill bit KEILRAPID	22
270 SDS-max W2 TURBOHEAD Xpro / TURBOKEIL X-shape	23-26
273 SDS-max TURBOCLEAN extraction drill bit	27
272 SDS-plus TURBOCLEAN extraction drill bit	28
269 SDS-max concrete milling cutter	29
259 Break-through core drill bit	31
259 Hammer hollow core	32-33
259 Adapters with Ratio thread	34
265 Adapter for SDS-plus	36
264 SDS-plus locating shanks for chucks	37

HAMMER DRILL BITS

Keil hammer drill bits are applicable for hardest materials. No matter if brick work, armed concrete, natural stone or artificial stone - our drill bits drill a geometrically exact hole in all kinds of material.

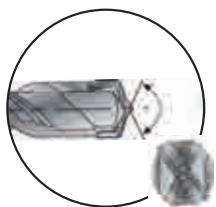

SDS-PLUS TURBOHEAD XPRO RS

Innovative X-head design with 4 cutting edges for fast and professional work. This rebar resistant hammer drill bit guarantees an even higher drilling speed and low wear. The special solid carbide head enables ideal spot drilling, while the optimised MS5 helix ensures rapid removal of drill dust and significantly less friction in the drill hole, resulting in low heat generation and low power consumption of the machine.

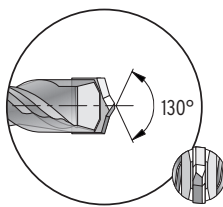

SDS-PLUS MS5 TURBOKEIL

The professional hammer drill bit generation can be used for hardest material in all hammer drilling machines. The TURBOKEIL drill bit with its centering tip does not even stop on armoured iron. Clean drilling holes can be made.

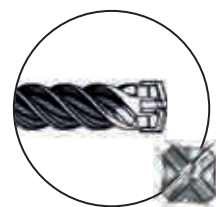

SDS-PLUS POWER-4CE

Robust multi-cutter for reinforced concrete with 4 cutting edges and 4 helices. The Power-4CE guarantees high wear resistance and excellent power transfer. Multiple-cutter head geometry prevents jamming on reinforcements and ensures a fast advance speed.

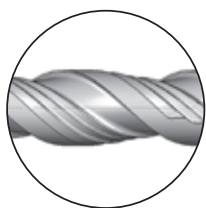

MS5 HELIX

The MS5 flute drills considerably faster than a normal flute. It has a longer service life and reduces the swinging and torsion forces caused during the hammer drilling. Therefore no jam of drilling dust occurs. It has a faster drilling speed and transfers the impact energy in an optimal way. The reinforced core and the rounded gradual transitions offer much more breaking strength.

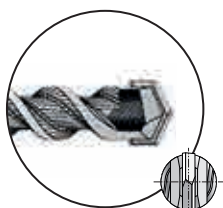

SDS-PLUS KEILRAPID

The reliable entry-level drill bit for all concrete and masonry applications.

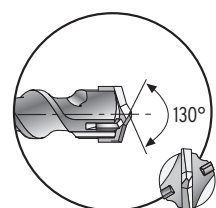

HAMMER DRILL BIT TURBOKEIL X-SHAPE

The symmetric X-shape of the 4-cutter drills provides exact and accurate holes and protects the drill bit of damage when it hits armoured iron. Its head construction minimizes the friction in the drilling hole.

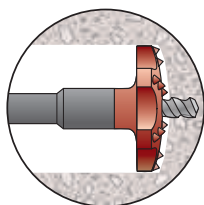

SYSTEM 259

Due to its stable construction the system 259 is suitable for highest demands. It is made of tempered steel and has extremely impact resistant carbide studs which have a high cut resistance. The high temperature brazing is made at 1,120° C in a two step special process.

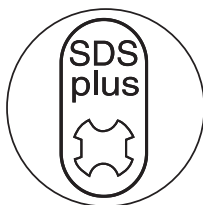

SDS-PLUS

The SDS-plus shaft is directly fitting into all hammer drilling machines with the SDS-plus and Hilti TE-C tool locking. The SDS-plus shaft is especially suitable for smaller drill bits and plug holes.

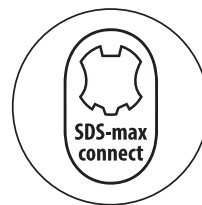
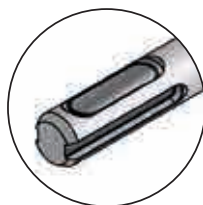

SDS-MAX

The SDS-max shaft is directly fitting into all hammer drilling machines with the SDS-max and Hilti TE-Y tool chuck. The SDS-max shaft is especially suitable for big drilling diameters and break through.



QUALITY MARK

The PGM quality mark stands for a high-quality product manufactured in a controlled and certified production. Drill bits with this seal drill geometrically exact holes. KEIL is a founding member of the PGM and is authorized to carry this seal - for more than 25 years.



LOW HAND-ARM-VIBRATION

If a person is continuously exposed to strong mechanical vibrations, this can have negative effects on his health. The operation of hammer drilling machines causes this kind of vibration. With specific design modifications we develop and optimise our quality products continuously in order to minimize the vibrations caused by the drilling tool.

Comment: Please take notice of „Guidelines 2002/44/EG“ for the maximum acceptable working period!

251 SDS-PLUS TURBOHEAD XPRO RS

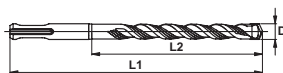

DRIVE



EXECUTION



- Made of tempered steel, shot-peened and intermediate level hardened
- TURBOHEAD Xpro head with centering tip
- TURBOHEAD Xpro with innovative 4-cutting-edge concept
- MS5 flute with reinforced core

FOR USE IN



APPLICATION

- Fits directly into all hammer drilling machines with SDS-plus and HILTI TE-C drive
- For drilling plug holes
- Particularly suitable for fastenings
- Adapters for SDS-plus [36]

PACKAGING

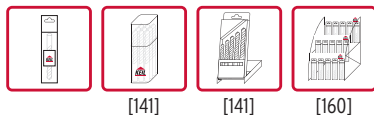

Comments

- More dimensions of the 4-cutter with X-shape on request
- For a working length of 400 mm and more, pre-drilling must be carried out to a depth of at least 150 mm with a drill bit of the same diameter.

D Ø mm	D Ø mm	L2 mm	L1 mm		EAN 4016707...	
5,0	3/16	50	110	10	902000	251 050 110
5,0	3/16	100	160	10	902017	251 050 160
5,0	3/16	150	210	10	902024	251 050 210
5,0	3/16	200	260	10	914553	251 050 260
5,5	7/32	50	110	10	912641	251 055 110
5,5	7/32	100	160	10	912634	251 055 160
5,5	7/32	150	210	10	912627	251 055 210
5,5	7/32	200	260	10	912757	251 055 260
6,0	15/64	50	110	10	902031	251 060 110
6,0	15/64	100	160	10	902048	251 060 160
6,0	15/64	150	210	10	902055	251 060 210
6,0	15/64	200	260	10	902062	251 060 260
6,5	1/4	100	160	10	904622	251 065 160
6,5	1/4	160	210	10	904639	251 065 210
6,5	1/4	200	260	10	904646	251 065 260
6,5	1/4	250	310	1	914560	251 065 310
8,0	5/16	50	110	10	902109	251 080 110
8,0	5/16	100	160	10	902116	251 080 160
8,0	5/16	150	210	10	902123	251 080 210
8,0	5/16	200	260	10	902130	251 080 260
8,0	5/16	250	310	1	904653	251 080 310
8,0	5/16	300	360	1	904660	251 080 360
8,0	5/16	400	460	1	904677	251 080 460
10,0	3/8	100	160	10	902154	251 100 160
10,0	3/8	150	210	10	902161	251 100 210
10,0	3/8	200	260	10	902178	251 100 260
10,0	3/8	250	310	1	902185	251 100 310
10,0	3/8	310	360	1	904684	251 100 360
10,0	3/8	400	460	1	902208	251 100 460
10,0	3/8	540	600	1	914577	251 100 600
12,0	15/32	100	160	10	902215	251 120 160
12,0	15/32	150	210	10	902222	251 120 210
12,0	15/32	200	260	10	902239	251 120 260
12,0	15/32	250	310	1	902246	251 120 310
12,0	15/32	400	450	1	902253	251 120 450
12,0	15/32	540	600	1	914584	251 120 600
14,0	17/32	100	160	10	902260	251 140 160
14,0	17/32	150	210	10	902277	251 140 210
14,0	17/32	200	260	10	902284	251 140 260
14,0	17/32	250	310	1	904691	251 140 310
14,0	17/32	400	450	1	902291	251 140 450
14,0	17/32	540	600	1	914591	251 140 600
16,0	39/64	100	160	1	904707	251 160 160
16,0	39/64	150	210	1	904714	251 160 210
16,0	39/64	200	260	1	904721	251 160 260
16,0	39/64	400	450	1	904738	251 160 450

251 SDS-PLUS TURBOHEAD XPRO RS

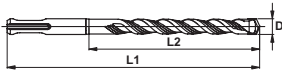

DRIVE



EXECUTION



- Made of tempered steel, shot-peened and intermediate level hardened
- TURBOHEAD Xpro head with centering tip
- TURBOHEAD Xpro with innovative 4-cutting-edge concept
- MS5 flute with reinforced core

FOR USE IN

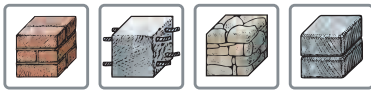

APPLICATION

- Fits directly into all hammer drilling machines with SDS-plus and HILTI TE-C drive
- For drilling plug holes
- Particularly suitable for fastenings
- Adapters for SDS-plus [36]

PACKAGING

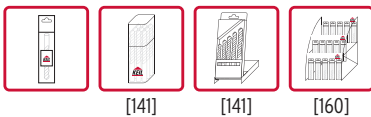

[141]

[141]

[160]

Comments

- More dimensions of the 4-cutter with X-shape on request
- For a working length of 400 mm and more, pre-drilling must be carried out to a depth of at least 150 mm with a drill bit of the same diameter.

D Ø mm	D Ø "	L2 mm	L1 mm	Icon	FAN 4016707...	Icon 12345
16,0	39/64	540	600	1	914607	251 160 600
18,0	11/16	200	250	1	914614	251 180 250
18,0	11/16	400	450	1	914737	251 180 450
20,0	49/64	200	250	1	914744	251 200 250
20,0	49/64	400	450	1	914751	251 200 450
20,0	49/64	550	600	1	914768	251 200 600



VIBRATION PROTECTION

Low vibration load of the „hand-arm-system“ by means of highly reduced vibration (see page 11). According to the European guideline EU-Vibrationsrichtlinie 2002/44/EG for vibration protection.

267 SDS-PLUS POWER-4CE



DRIVE

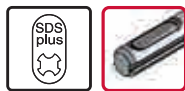

EXECUTION



- Optimum advance and long service life thanks to 4-cutter carbide head
- No snagging on reinforcements due to multiple-cutter head
- Fast drill dust transport thanks to high-volume 4-helix spiral
- Precise positioning thanks to strong centring tip

FOR USE IN



APPLICATION

- Fits directly into all hammer drills with SDS-plus and HILTI TE-C mounting
- For drilling dowel holes
- Especially suitable for fastening technology
- Coupling for SDS-plus [36]

PACKAGING

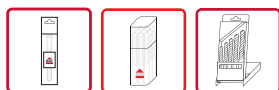

D Ø mm	D Ø "	L2 mm	L1 mm		EAN 4016707...	 12345
5,0	3/16	50	110	1	923838	267 050 110
5,0	3/16	100	160	1	923845	267 050 160
5,0	3/16	150	210	1	923852	267 050 210
5,0	3/16	250	310	1	923869	267 050 310
5,5	7/32	50	110	1	923876	267 055 110
5,5	7/32	100	160	1	923883	267 055 160
5,5	7/32	150	210	1	923890	267 055 210
6,0	15/64	50	110	1	923906	267 060 110
6,0	15/64	100	160	1	923913	267 060 160
6,0	15/64	150	210	1	923920	267 060 210
6,0	15/64	200	260	1	923937	267 060 260
6,0	15/64	250	310	1	923944	267 060 310
6,0	15/64	400	460	1	923951	267 060 460
6,5	1/4	50	110	1	923968	267 065 110
6,5	1/4	100	160	1	923975	267 065 160
6,5	1/4	150	210	1	923982	267 065 210
6,5	1/4	200	260	1	923999	267 065 260
7,0	9/32	50	110	1	924002	267 070 110
7,0	9/32	100	160	1	924019	267 070 160
7,0	9/32	150	210	1	924026	267 070 210
7,0	9/32	200	260	1	924033	267 070 260
7,0	9/32	250	310	1	924040	267 070 310
8,0	5/16	50	110	1	924057	267 080 110
8,0	5/16	100	160	1	924064	267 080 160
8,0	5/16	150	210	1	924071	267 080 210
8,0	5/16	200	260	1	924088	267 080 260
8,0	5/16	250	310	1	924095	267 080 310
8,0	5/16	400	460	1	924101	267 080 460
8,0	5/16	550	600	1	924118	267 080 600
8,0	5/16	900	950	1	924125	267 080 950
10,0	3/8	50	110	1	924132	267 100 110
10,0	3/8	100	160	1	924149	267 100 160
10,0	3/8	150	210	1	924156	267 100 210
10,0	3/8	200	260	1	924163	267 100 260
10,0	3/8	250	310	1	924170	267 100 310
10,0	3/8	400	460	1	924187	267 100 460
10,0	3/8	550	600	1	924194	267 100 600
10,0	3/8	950	1000	1	924200	267 101 000
12,0	15/32	100	160	1	924217	267 120 160
12,0	15/32	150	210	1	924224	267 120 210
12,0	15/32	200	260	1	924231	267 120 260
12,0	15/32	250	310	1	924248	267 120 310
12,0	15/32	400	450	1	924255	267 120 450
12,0	15/32	550	600	1	924262	267 120 600
12,0	15/32	950	1000	1	924279	267 121 000
14,0	17/32	100	160	1	924286	267 140 160

267 SDS-PLUS POWER-4CE



DRIVE



EXECUTION



- Optimum advance and long service life thanks to 4-cutter carbide head
- No snagging on reinforcements due to multiple-cutter head
- Fast drill dust transport thanks to high-volume 4-helix spiral
- Precise positioning thanks to strong centring tip

FOR USE IN



APPLICATION

- Fits directly into all hammer drills with SDS-plus and HILTI TE-C mounting
- For drilling dowel holes
- Especially suitable for fastening technology
- Coupling for SDS-plus [36]

PACKAGING

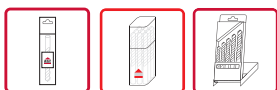

D Ø mm	D Ø "	L2 mm	L1 mm		 EAN 4016707...	 12345
14,0	17/32	150	200	1	924293	267 140 200
14,0	17/32	200	250	1	924309	267 140 250
14,0	17/32	250	300	1	924316	267 140 300
14,0	17/32	400	450	1	924323	267 140 450
14,0	17/32	550	600	1	924330	267 140 600
16,0	39/64	150	200	1	924347	267 160 200
16,0	39/64	200	250	1	924354	267 160 250
16,0	39/64	250	300	1	924361	267 160 300
16,0	39/64	400	450	1	924378	267 160 450
16,0	39/64	550	600	1	924385	267 160 600
16,0	39/64	950	1000	1	924392	267 161 000

252 SDS-PLUS W2 HAMMER DRILL BIT X-SHAPE



DRIVE

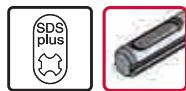

EXECUTION



- Made of tempered steel, shot-peened and intermediate level hardened
- TURBOKEIL carbide plate with centring tip
- 4-cutting edges with W2 flute
- Specially designed head geometry for better center drilling, faster drilling progress, precise drilling hole

FOR USE IN



APPLICATION

- Fits directly into all hammer drilling machines with SDS-plus and HILTI TE-C drive
- For drilling plug holes
- Particularly suitable for fastenings
- Adapters for SDS-plus [36]

PACKAGING



Comments

- More dimensions of the 4-cutter page 12 or on request

D Ø mm	D Ø "	L2 mm	L1 mm		EAN 4016707...	 12345
22,0	7/8	400	450	1	326066	252 122 450
24,0	15/16	400	450	1	326073	252 124 450
25,0	1	400	450	1	326080	252 125 450
28,0	1 1/8	400	450	1	326097	252 128 450
30,0	1 3/16	400	450	1	326103	252 130 450

SDS-PLUS W2 TURBOKEIL X-SHAPE

- The symmetrical X-shape tip construction of the 4-cutting edges with one main cutter and two auxiliary cutters provides for accurate and correct guidance of the drill bit.
- The geometry with 4-cutting edges protects the bit against damage when impacting on armouring iron.
- The design of the head construction significantly decreases friction in the hole so that the tool life is considerably extended.
- Short flute entries and large volume borehole cut channels in the double spiral provide for fast spoil removal.
- Stability against torsional loads
- Precise hole
- Reduced noise emissions
- Rapid spoil removal due to large grooves and double helix
- Protection of man and machine
- Noticeably longer life

A few advantages of the 4-cutting edges:

- Optimum vibration behaviour
- Reduced friction
- Maximum transfer of energy
- Guided centrally



VIBRATION PROTECTION

Low vibration load of the „hand-arm-system“ by means of highly reduced vibration (see page 11). According to the European guideline EU-Vibrationsrichtlinie 2002/44/EG for vibration protection.

253 SDS-PLUS MS5 TURBOKEIL



DRIVE



EXECUTION



- Made of tempered steel, shot-peened and intermediate level hardened
- TURBOKEIL carbide plate with centring tip
- MS5 flute

FOR USE IN

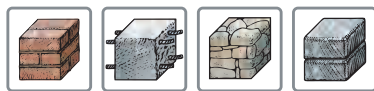

APPLICATION

- Fits directly into all hammer drilling machines with SDS-plus and HILTI TE-C drive
- For drilling plug holes
- Particularly suitable for fastenings
- Adapters for SDS-plus [36]

PACKAGING

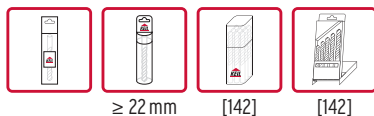

≥ 22 mm

[142]

[142]



[160]

Comments

- For a working length of 400 mm and more, predrilling must be carried out to a depth of at least 150 mm with a drill bit of the same diameter.
- For a working length of 950 mm, pre-drilling must be carried out to a depth of at least 400 mm with a short drill bit of the same diameter.
- The warranty does not apply to extra-long drill bits of 1,000 mm and more.
- Other dimensions on request

D ø mm	D ø''	L2 mm	L1 mm	Icons	FAN 4016707...	12345
3,5	9/64	35	100	10	323751	253 035 100
4,0	5/32	50	110	10	322136	253 040 110
4,0	5/32	100	160	10	328008	253 040 160
5,0	3/16	50	110	10	322006	253 050 110
5,0	3/16	100	160	10	322013	253 050 160
5,0	3/16	150	210	10	323560	253 050 210
5,0	3/16	200	260	10	324307	253 050 260
5,0	3/16	260	310	1	904769	253 050 310
5,0	3/16	350	410	1	904776	253 050 410
5,5	7/32	50	110	10	322952	253 055 110
5,5	7/32	100	160	10	322969	253 055 160
5,5	7/32	200	260	10	322976	253 055 260
6,0	15/64	50	110	10	322020	253 060 110
6,0	15/64	70	135	10	328015	253 060 135
6,0	15/64	100	160	10	322037	253 060 160
6,0	15/64	150	210	10	320903	253 060 210
6,0	15/64	200	260	10	320910	253 060 260
6,0	15/64	300	360	1	323768	253 060 360
6,0	15/64	400	460	1	328022	253 060 460
6,5	1/4	50	110	10	322143	253 065 110
6,5	1/4	100	160	10	322150	253 065 160
6,5	1/4	150	210	10	328039	253 065 210
6,5	1/4	200	260	10	328046	253 065 260
7,0	9/32	50	110	10	322167	253 070 110
7,0	9/32	100	160	10	322174	253 070 160
8,0	5/16	50	110	10	322044	253 080 110
8,0	5/16	100	160	10	322051	253 080 160
8,0	5/16	150	210	10	322068	253 080 210
8,0	5/16	200	260	10	320927	253 080 260
8,0	5/16	250	310	1	328060	253 080 310
8,0	5/16	400	460	1	323546	253 080 460
8,0	5/16	550	600	1	323775	253 080 600
9,0	11/32	100	160	10	323232	253 090 160
9,0	11/32	200	260	10	328077	253 090 260
10,0	3/8	50	110	10	322181	253 100 110
10,0	3/8	100	160	10	322075	253 100 160
10,0	3/8	150	210	10	322082	253 100 210
10,0	3/8	200	260	10	320934	253 100 260
10,0	3/8	250	310	1	328084	253 100 310
10,0	3/8	300	360	1	328091	253 100 360
10,0	3/8	350	410	1	328107	253 100 410
10,0	3/8	400	460	1	320941	253 100 460
10,0	3/8	550	600	1	328114	253 100 600
10,0	3/8	950	1.000	1	328121	253 101 000
11,0	13/32	100	160	10	328138	253 110 160
11,0	13/32	200	260	10	328145	253 110 260

253 SDS-PLUS MS5 TURBOKEIL

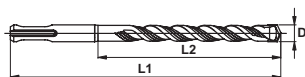

DRIVE

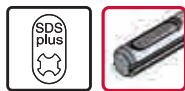

EXECUTION



- Made of tempered steel, shot-peened and intermediate level hardened
- TURBOKEIL carbide plate with centring tip
- MS5 flute

FOR USE IN

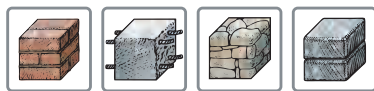

APPLICATION

- Fits directly into all hammer drilling machines with SDS-plus and HILTI TE-C drive
- For drilling plug holes
- Particularly suitable for fastenings
- Adapters for SDS-plus [36]

PACKAGING

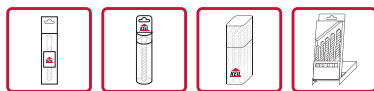

≥ 22mm

[142]

[142]



[160]

Comments

- For a working length of 400 mm and more, predrilling must be carried out to a depth of at least 150 mm with a drill bit of the same diameter.
- For a working length of 950 mm, pre-drilling must be carried out to a depth of at least 400 mm with a short drill bit of the same diameter.
- The warranty does not apply to extra-long drill bits of 1,000 mm and more.
- Other dimensions on request

D Ø mm	D Ø "	L2 mm	L1 mm		EAN 4016707...	 12345
12,0	15/32	100	160	10	322099	253 120 165
12,0	15/32	150	210	10	322105	253 120 215
12,0	15/32	200	260	10	320958	253 120 265
12,0	15/32	250	310	1	328152	253 120 310
12,0	15/32	350	400	1	328169	253 120 400
12,0	15/32	400	450	1	320965	253 120 450
12,0	15/32	550	600	1	328176	253 120 600
12,0	15/32	950	1.000	1	328183	253 121 000
13,0	1/2	100	160	10	328190	253 130 160
13,0	1/2	200	260	10	328206	253 130 265
14,0	17/32	100	160	10	322198	253 140 165
14,0	17/32	150	210	10	322204	253 140 215
14,0	17/32	200	260	10	320972	253 140 265
14,0	17/32	250	310	1	328213	253 140 310
14,0	17/32	400	450	1	320989	253 140 450
14,0	17/32	550	600	1	328220	253 140 600
14,0	17/32	950	1.000	1	328237	253 141 000
15,0	19/32	100	160	10	328244	253 150 160
15,0	19/32	150	210	10	328251	253 150 210
15,0	19/32	200	260	10	328268	253 150 260
15,0	19/32	400	450	1	323782	253 150 450
16,0	39/64	100	160	10	322662	253 160 165
16,0	39/64	150	210	10	322679	253 160 215
16,0	39/64	200	260	10	320996	253 160 265
16,0	39/64	250	310	1	328275	253 160 310
16,0	39/64	350	400	1	328282	253 160 400
16,0	39/64	400	450	1	321009	253 160 450
16,0	39/64	550	600	1	328299	253 160 600
16,0	39/64	750	800	1	328305	253 160 800
16,0	39/64	950	1.000	1	328312	253 161 000
17,0	21/32	150	210	5	328329	253 170 200
18,0	11/16	150	200	5	323256	253 180 200
18,0	11/16	250	300	1	328336	253 180 300
18,0	11/16	400	450	1	323263	253 180 450
18,0	11/16	550	600	1	323270	253 180 600
18,0	11/16	950	1.000	1	323430	253 181 000
19,0	23/32	200	250	5	323287	253 190 250
19,0	23/32	400	450	1	323294	253 190 450
20,0	49/64	150	200	5	323300	253 200 200
20,0	49/64	250	300	1	323317	253 200 300
20,0	49/64	400	450	1	323324	253 200 450
20,0	49/64	550	600	1	323331	253 200 600
20,0	49/64	950	1.000	1	323447	253 201 000
22,0	27/32	200	250	1	323348	253 220 250
22,0	27/32	400	450	1	323355	253 220 450
22,0	27/32	550	600	1	323362	253 220 600

253 SDS-PLUS MS5 TURBOKEIL

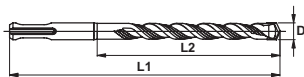

DRIVE



EXECUTION



- Made of tempered steel, shot-peened and intermediate level hardened
- TURBOKEIL carbide plate with centring tip
- MS5 flute

FOR USE IN



APPLICATION

- Fits directly into all hammer drilling machines with SDS-plus and HILTI TE-C drive
- For drilling plug holes
- Particularly suitable for fastenings
- Adapters for SDS-plus [36]

PACKAGING

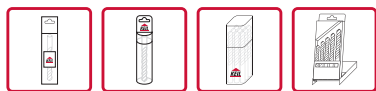

≥ 22mm

[142]

[142]



[160]

Comments

- For a working length of 400 mm and more, predrilling must be carried out to a depth of at least 150 mm with a drill bit of the same diameter.
- For a working length of 950 mm, pre-drilling must be carried out to a depth of at least 400 mm with a short drill bit of the same diameter.
- The warranty does not apply to extra-long drill bits of 1,000 mm and more.
- Other dimensions on request

D Ø mm	D Ø "	L2 mm	L1 mm	Icon	FAN 4016707...	Icon 12345
22,0	27/32	950	1.000	1	323454	253 221 000
24,0	59/64	200	250	1	323379	253 240 250
24,0	59/64	400	450	1	323386	253 240 450
25,0	31/32	200	250	1	323393	253 250 250
25,0	31/32	400	450	1	323409	253 250 450
25,0	31/32	950	1.000	1	323799	253 251 000
26,0	1	100	160	1	323980	253 260 160
26,0	1	200	250	1	323416	253 260 250
26,0	1	400	450	1	323423	253 260 450

SDS-PLUS MS5 TURBOKEIL

The new KEIL hammer drill bit generation can be used for the hardest materials in all SDS-plus hammer drilling machines. **TURBOKEIL** with centring tip for precisely drilling.

Features:

- Centring tip
- Guided Carbide plate
- Strengthened carbide tip
- Large cutting angle
- Clean drill holes
- Drilling with the utmost precision

MS5 spiral for ergonomic and ecological work flow:

- High drilling speed
- Fast transport of drilling dust
- High grade of stiffness and long service life
- High resistance against breakage

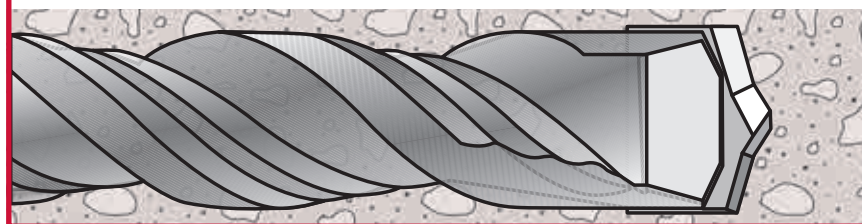

SDS-PLUS MS5 RS

MULTI STEP FLUTE

∅ mm	Spiral Steps
4 - 5	2
6 - 7	4
8 - 9	6
10 - 12	8
13 - 14	6
15 - 16	8
17 - 26	10



The MS5 helix is protected by patent. The number of spiral steps and radiuses on the drill depends on the diameter.

Due to its computer-optimised geometry, the RS spiral ensures optimal drill dust transport and minimises the deflagration effect. This significantly increases the drilling speed.

COMPARATIVE DRILLING

Working professionally means working economically

This shows the comparative drilling with the MS5 Multi-step helix and a traditional helix. Hole depth for drilling time of 15 seconds, using SDS-plus hammer drill bits TURBOKEIL 6 x 100 x 160 mm in B25 concrete.

64 % faster with Multi-step helix!
Twice as fast with RS spiral!

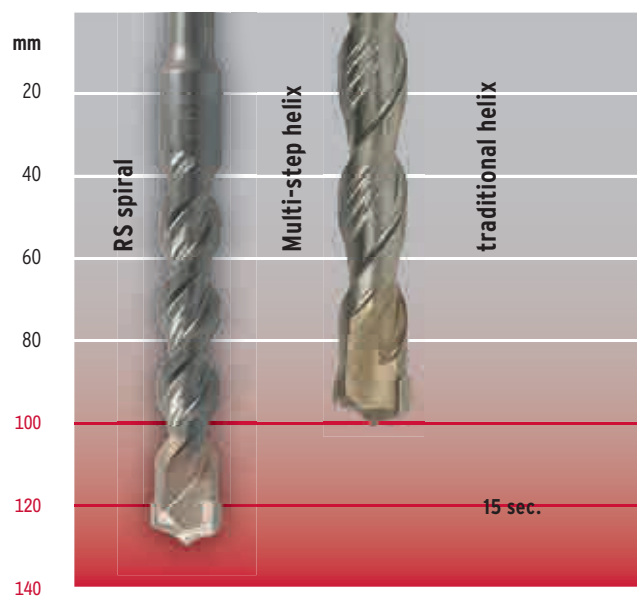

ADVANTAGES

Longer service life

The RS helix reduces the vibration loads generated during drilling.

No accumulation of spoil

The RS helix reduces the torsion loads generated during drilling and transports drilling dust optimally.

High drilling speed

The RS helix provides for optimum transfer of the impact energy of the hammer drilling machine. High drilling speed.

Extreme fracture resistance

The RS helix has a strengthened core and rounded step transitions.



SMART TOOLS FOR SMART PEOPLE

HAMMER DRILL BITS

CHISELS

STONE AND
SPECIAL DRILL BITS

METAL DRILL BITS

WOOD DRILL BITS

SAWS

ASSORTMENTS

MODULES



256 SDS-PLUS HAMMER DRILL BITS KEILRAPID

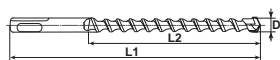

DRIVE



EXECUTION



- Robust hard carbide plate with 130° tip
- Aggressive tip and helix design
- Low-vibration operation

FOR USE IN



APPLICATION

- Reliable entry-level hammer drill bits for all concrete and stone applications
- For drilling into masonry, concrete, aerated concrete and sand lime brick
- Adapter for SDS-plus [36]

PACKAGING

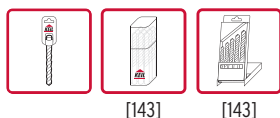

[143]

[143]

D Ø mm	D Ø "	L2 mm	L1 mm		EAN 4016707...	12345
4	5/32	50	110	10	918889	256 040 110
4	5/32	100	160	10	918896	256 040 160
5	3/16	50	110	10	918902	256 050 110
5	3/16	100	160	10	918919	256 050 160
5,5	7/32	50	110	10	918926	256 055 110
5,5	7/32	100	160	10	918933	256 055 160
5,5	7/32	150	210	10	918940	256 055 210
6	15/64	50	110	10	918957	256 060 110
6	15/64	100	160	10	918971	256 060 160
6	15/64	150	210	10	918988	256 060 210
6	15/64	200	260	10	918995	256 060 260
6,5	1/4	100	160	10	919008	256 065 160
6,5	1/4	150	210	10	919015	256 065 210
7	9/32	100	160	10	919022	256 070 160
7	9/32	150	210	10	919039	256 070 210
8	5/16	50	110	10	919046	256 080 110
8	5/16	100	160	10	919053	256 080 160
8	5/16	150	210	10	919060	256 080 210
8	5/16	200	260	10	919077	256 080 260
9	11/32	100	160	10	919084	256 090 160
10	3/8	50	110	10	919091	256 100 110
10	3/8	100	160	10	919114	256 100 160
10	3/8	150	210	10	919121	256 100 210
10	3/8	200	260	10	919138	256 100 260
10	3/8	250	310	1	919145	256 100 310
10	3/8	400	450	1	919152	256 100 450
11	13/32	250	310	1	919169	256 110 310
12	15/32	100	160	10	919176	256 120 160
12	15/32	150	210	10	919183	256 120 210
12	15/32	200	260	10	919190	256 120 260
12	15/32	250	310	10	919206	256 120 310
12	15/32	400	450	10	919213	256 120 450
14	17/32	100	160	10	919220	256 140 160
14	17/32	150	210	10	919237	256 140 210
14	17/32	200	250	10	919244	256 140 250
14	17/32	250	310	1	919251	256 140 310
14	17/32	400	450	1	919268	256 140 450
16	39/64	100	160	10	919275	256 160 160
16	39/64	150	210	10	919282	256 160 210
16	39/64	250	300	1	919299	256 160 300
16	39/64	400	450	1	919305	256 160 450
18	11/16	200	260	1	919312	256 180 260
18	11/16	250	300	1	919329	256 180 300
18	11/16	400	450	1	919336	256 180 450
20	49/64	250	300	1	919343	256 200 300
20	49/64	400	450	1	919350	256 200 450
22	27/32	400	450	1	919367	256 220 450
25	1	400	450	1	919374	256 250 450

270 SDS-MAX W2 TURBOHEAD XPRO / TURBOKEIL X-SHAPE

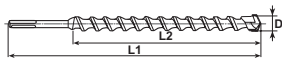

DRIVE



EXECUTION



- Made of tempered steel, shot-peened and hardened
- 4 cutter TUBOHEAD Xpro with full carbide head up to 20 mm (15 mm only available with 2 cutting edges)
- 4 cutter with 1 main and 2 strengthened side cutters
- Specially designed head geometry for better center drilling, faster drilling progress, precise drilling hole

FOR USE IN



APPLICATION

- Fits directly into SDS-max and HILTI TE-Y locking

PACKAGING



against surcharge [161]

Comments

- For a working length of 400 mm and more, pre-drilling must be carried out to a depth of at least 150 mm with a drill bit of the same diameter.
- For a working length of 800 mm and more, pre-drilling must be carried out to a depth of at least 400 mm with a short drill bit of the same diameter.
- Other dimensions on request

D ø mm	D ø "	L2 mm	L1 mm	2 /4		EAN 4016707	
8,0	5/16	200	340	4	1	914775	270 080 341
10,0	3/8	200	340	4	1	914782	270 100 341
12,0	15/32	200	340	4	1	914799	270 120 341
12,0	15/32	400	540	4	1	914805	270 120 541
12,0	15/32	550	690	4	1	914812	270 120 691
14,0	9/16	200	340	4	1	914829	270 140 341
14,0	9/16	400	540	4	1	914836	270 140 541
15,0	19/32	200	340	2	1	360282	270 150 340
15,0	19/32	400	540	2	1	360459	270 150 540
16,0	5/8	200	340	4	1	914843	270 160 341
16,0	5/8	400	540	4	1	914850	270 160 541
16,0	5/8	800	940	4	1	914867	270 160 941
18,0	11/16	200	340	4	1	914874	270 180 341
18,0	11/16	400	540	4	1	914881	270 180 541
18,0	11/16	800	940	4	1	914898	270 180 941
20,0	3/4	200	320	4	1	914904	270 200 321
20,0	3/4	400	520	4	1	914911	270 200 521
20,0	3/4	800	920	4	1	914928	270 200 921
20,0	3/4	1200	1320	4	1	914935	270 201 321
22,0	7/8	200	320	4	1	360114	270 220 320
22,0	7/8	400	520	4	1	360121	270 220 520
22,0	7/8	800	920	4	1	360398	270 220 920
22,0	7/8	1200	1320	4	1	360756	270 221 320
24,0	15/16	200	320	4	1	360138	270 240 320
24,0	15/16	400	520	4	1	360367	270 240 520
25,0	1	200	320	4	1	360145	270 250 320
25,0	1	400	520	4	1	360152	270 250 520
25,0	1	800	920	4	1	360169	270 250 920
25,0	1	1200	1320	4	1	360428	270 251 320
28,0	11/8	250	370	4	1	360176	270 280 370
28,0	11/8	450	570	4	1	360183	270 280 570
28,0	11/8	550	670	4	1	360848	270 280 670
30,0	13/16	250	370	4	1	360190	270 300 370
30,0	13/16	450	570	4	1	360206	270 300 570
32,0	11/4	250	370	4	1	360213	270 320 370
32,0	11/4	450	570	4	1	360220	270 320 570
32,0	11/4	800	920	4	1	360237	270 320 920
32,0	11/4	1200	1320	4	1	360435	270 321 320
35,0	13/8	250	370	4	1	360244	270 350 370
35,0	13/8	450	570	4	1	360251	270 350 570
38,0	11/2	250	370	4	1	360268	270 380 370
38,0	11/2	450	570	4	1	360275	270 380 570
40,0	19/16	250	370	4	1	360862	270 400 370
40,0	19/16	450	570	4	1	360299	270 400 570
40,0	19/16	800	920	4	1	360404	270 400 920
40,0	19/16	1200	1320	4	1	360442	270 401 320

270 SDS-MAX W2 TURBOHEAD XPRO / TURBOKEIL X-SHAPE

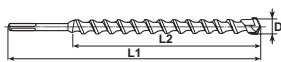

DRIVE



D Ø mm	D Ø "	L2 mm	L1 mm	2/4		EAN 4016707...	
45,0	1 3/4	450	570	4	1	360763	270 450 570
45,0	1 3/4	800	920	4	1	360770	270 450 920
50,0	2	450	570	4	1	360794	270 500 570

EXECUTION



- Made of tempered steel, shot-peened and hardened
- TURBOKEIL carbide plate with centring tip
- 2-cutting edge system with W2 flute up to 15mm
- 4-cutting edge system with W2 flute from 16mm
- Specially designed head geometry for better center drilling, faster drilling progress, precise drilling hole

FOR USE IN



APPLICATION

- Fits directly into SDS-max and HILTI TE-Y locking

PACKAGING



against
surcharge

[161]

Comments

- For a working length of 400 mm and more, pre-drilling must be carried out to a depth of at least 150 mm with a drill bit of the same diameter.
- For a working length of 800 mm and more, pre-drilling must be carried out to a depth of at least 400 mm with a short drill bit of the same diameter.
- Other dimensions on request

SDS-MAX W2 TURBOKEIL X-SHAPE

- The symmetrical X-shape tip construction of the 4-cutting edges with one main cutter and two auxiliary cutters provides for accurate and correct guidance of the drill bit.
- The geometry with 4-cutting edges protects the bit against damage when impacting on armouring iron.
- The design of the head construction significantly decreases friction in the hole so that the tool life is considerably extended.
- Short flute entries and large volume borehole cut channels in the double spiral provide for fast spoil removal.

A few advantages of the 4-cutting edges

- Maximum transfer of energy
- Guided centrally
- Optimum vibration behaviour
- Reduced friction
- Stability against torsional loads
- Precise hole
- Optimum spoil removal due to large grooves and double helix
- Protection of operator and machine
- Reduced noise emissions
- Noticeably longer life



VIBRATION PROTECTION

Low vibration load of the „hand-arm-system“ by means of highly reduced vibration (see page 11). According to the European guideline EU-Vibrationsrichtlinie 2002/44/EG for vibration protection.

SDS-MAX W2

TURBOHEAD XPRO AND TURBOKEIL X-SHAPE



OPTIMIZED DESIGN

FASTER

- Up to 20 % faster drilling progress due to perfect head shape and large entry grooves for better admission of drill dust



STRONGER

- Equipped with full carbide head for strongest performance already from 8 mm
- From 22 mm with strengthened side cutters for more stability and longer tool life
- Symmetric X-head-shape with TURBOKEIL centring tip and more efficiency when hitting reinforced steel

PRODUCT INFORMATION

- The symmetric form of the full carbide head TURBOHEAD Xpro (up to 20 mm diameter) and also the TURBOKEIL X-shape (from 22 mm diameter) provide accurate and correct guidance of the drill bit.
- The geometry with 4-cutting edges protects the bit against damage when impacting on armouring iron.
- The design of the head construction significantly decreases friction in the hole so that the tool life is considerably extended.
- Short flute entries and large volume borehole cut channels in the double spiral provide for fast spoil removal.



SDS-MAX W2

TURBOHEAD XPRO AND TURBOKEIL X-SHAPE

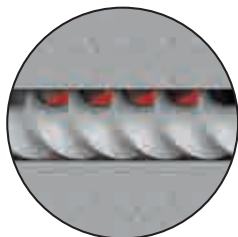

APPROVED DOUBLE FLUTE W2

- The fine tuned and flat angle of twist with its optimum combination of axial run-out and radial run-out takes care for a self-maintained flow of drill dust.
- These drill bits have the approved asymmetric W-flute in double execution.
- The drill dust is taken from the paddle-shaped notch and is optimally transported.
- The chip transporting notches leave a clean drill hole.

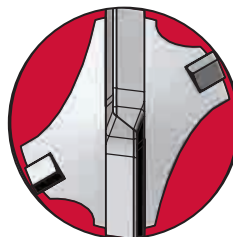

LARGE ENTRY GROOVES

- Approx. 40 % more space for drilling dust due to ellipsis shape of the milled grooves. This becomes a noticeable advantage especially with deep drill holes and soft concrete or stone.
- The X-shape provides a better admission of the drill dust.

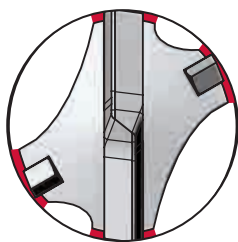

SYMMETRIC X-HEAD-SHAPE

- Reduced perimeter surface.
- Considerably less friction.
- Fast transport of drill dust and optimum pilot drilling.
- Fast drilling process and less wear.
- Develops low temperature with less power input.



LOW VIBRATION IN DRILLING

- Optimised vibrational characteristics.
- Maximum drill- and transportation power.
- Resistant against extreme torsion force.
- Reduced noise level while drilling.
- Less strain for user and machine.

273 SDS-MAX TURBOCLEAN EXTRACTION DRILL BIT



DRIVE



EXECUTION



- Dust-free drilling: 98% of the drilling dust is removed in the place it originates at the drill tip
- Drilling and vacuum cleaning in one step
- Reduced drilling friction thanks to extra large openings at the tip and internally routed drilling dust
- SDS-max shank

FOR USE IN



APPLICATION

- For installing the chemical anchors
- Drilling in interior applications
- Drilling into masonry, brick, concrete, granite, natural stone and sand lime brick

PACKAGING



D Ø mm	D Ø "	L2 mm	L1 mm	Box	EAN 4016707...	12345
14,0	17/32	400	600	1	919480	273 140 600
16,0	39/64	400	600	1	919497	273 160 600
18,0	11/16	400	600	1	919503	273 180 600
20,0	49/64	400	600	1	919510	273 200 600
22,0	27/32	400	600	1	919527	273 220 600
24,0	59/64	400	600	1	919534	273 240 600
25,0	31/32	400	600	1	919541	273 250 600
28,0	11/8	400	600	1	919558	273 280 600
30,0	13/16	400	600	1	919565	273 300 600
32,0	11/4	400	600	1	919572	273 320 600
35,0	1 3/8	400	600	1	919589	273 350 600
SDS-max TURBOCLEAN ADAPTER				1	919596	273 000 001



TURBOCLEAN ADAPTER

- The TURBOCLEAN combines drilling and dust extraction in a single step for all concrete work
- Dust-free drilling in compliance with current, more stringent health protection standards
- Removes 98% of drilling dust where it originates at the drill tip
- Rugged design of the drill head and shaft for a long service life
- Maximum productivity when setting chemical anchors
- Fast thanks to extra large openings at the tip and reduced drilling resistance as drilling dust is routed internally
- Saves annoying cleaning of the environment (important in sensitive environments such as hospitals, offices, etc.)
- Perfect for use in interior applications

272 SDS-PLUS TURBOCLEAN EXTRACTION DRILL BIT



DRIVE

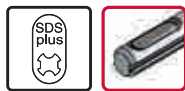

EXECUTION



- Dust-free drilling: 98 % of the drilling dust is removed in the place it originates at the drill tip
- Drilling and vacuum cleaning in one step
- Reduced drilling friction thanks to extra large openings at the tip and internally routed drilling dust
- SDS-plus shank

FOR USE IN



APPLICATION

- For installing the chemical anchors
- Drilling in interior applications
- Drilling into masonry, brick, concrete, granite, natural stone and sand lime brick

PACKAGING



D Ø mm	D Ø "	L2 mm	L1 mm		EAN 4016707...	 12345
6	15/64	100	220	1	924408	272 060 220
8	5/16	100	220	1	924415	272 080 220
8	5/16	150	270	1	919381	272 080 270
10	3/8	100	220	1	924422	272 100 220
10	3/8	150	270	1	919398	272 100 270
12	15/32	200	320	1	919404	272 120 320
14	17/32	250	370	1	919411	272 140 370
16	39/64	250	370	1	919428	272 160 370
18	11/16	250	370	1	919435	272 180 370
20	49/64	250	370	1	919442	272 200 370
24	59/64	250	370	1	919459	272 240 370
SDS-plus TURBOCLEAN ADAPTER				1	919466	272 000 001
SDS-plus TURBOCLEAN ADAPTER for DIA 6-8-10 in 220 mm L1				1	924439	272 000 002
Basic SET DIA 6-8-10 x 220 mm, incl. Adapter in case					924446	272 610 220



TURBOCLEAN ADAPTER

- The TURBOCLEAN combines drilling and dust extraction in a single step for all concrete work
- Dust-free drilling in compliance with current, more stringent health protection standards
- Removes 98 % of drilling dust where it originates at the drill tip
- Rugged design of the drill head and shaft for a long service life
- Maximum productivity when setting chemical anchors
- Fast thanks to extra large openings at the tip and reduced drilling resistance as drilling dust is routed internally
- Saves annoying cleaning of the environment (important in sensitive environments such as hospitals, offices, etc.)
- Perfect for use in interior applications

269 SDS-MAX CONCRETE MILLING CUTTER

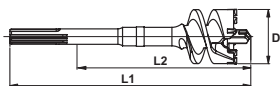

DRIVE



EXECUTION

- Solid construction in one piece
- Shot-peened and rust protected
- Made of tempered steel

FOR USE IN



APPLICATION

- Fits directly into SDS-max and HILTI TE-Y locking

PACKAGING



Comments

- Other dimensions on request

D Ø mm	D "	L2 mm	L1 mm	Box	FAN 4016707...	12345
55,0	2 3/16	480	590	1	91808	269 551 590
55,0	2 3/16	880	990	1	91809	269 551 990
65,0	2 5/8	480	590	1	91807	269 651 590
65,0	2 5/8	880	990	1	91810	269 651 990
80,0	3 1/8	480	590	1	91811	269 801 590
80,0	3 1/8	880	990	1	91812	269 801 990

SDS-MAX CONCRETE MILLING CUTTER

Due to increasing challenges in practical work our Keil concrete milling cutter was constructed in a new way. Therefore the concrete milling cutter drills faster in concrete and due to its more stable and larger number of solid carbide cutters it is less sensible against break-outs and wear. Also when hitting armouring iron the new concrete milling cutter shows its new features clearly.



Advantages for professional users:

- Percussive energy is transferred to the tool without loss
- Low weight
- Reduced vibration
- Long tool life
- Exact drill hole geometry



VIBRATION PROTECTION

Low vibration load of the „hand-arm-system“ by means of highly reduced vibration (see page 11). According to the European guideline EU-Vibrationsrichtlinie 2002/44/EG for vibration protection.

KEIL SPECIAL TOOLS

If you are looking for products which cope with your particular exigencies or products which are required for special fields of application, do not hesitate to contact us.

In addition to our standard articles we develop and manufacture special tools in close collaboration with you which represent accurately fitting solutions to your requirements.

SDS-PLUS & A-KONUS MS5 HAMMERBOHRER SONDERPRODUKTE

DRIVE



EXECUTION



- Optionally with a stop collar for precise depth limitation or with a cutting collar for optimum penetration of insulation materials

FOR USE IN



APPLICATION

- For drilling plug holes
- Particularly suitable for fastening technology

PACKAGING

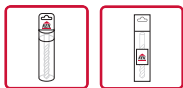

DRIVE / PACKAGING



SDS-PLUS MS5 COLLAR HAMMER DRILL BIT



A-CONE MS5 COLLAR HAMMER DRILL BIT



A-CONE MS5 HAMMER DRILL BIT



Working length up to collar in mm

Production to order, delivery time on request, minimum order quantity of 100 pcs. per desired item. Other sizes available upon request.

Ø mm	5	6	6,5	8	10
Ø ANSI	3/16"	15/64"	1/4"	5/16"	3/8"

SDS-PLUS DRILL EXTENSION FOR A-CONE DRILL BITS

incl. drift



SDS-plus drill rods for A-cone drill bits

Production to order, delivery time approx. 8 working weeks after confirmation, minimum order quantity of 100 pcs. per desired item.

Total length mm	270	500	650	800
-----------------	-----	-----	-----	-----

CHARACTERISTICS

- Increases the operation distance
- Cost savings by exchangeability of the drill bit
- Optimum transmission of the impact energy
- Long service life

259 BREAK-THROUGH CORE DRILL BIT TYPE S WITH RATIO THREAD

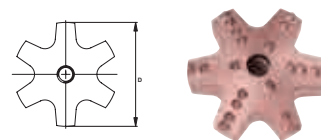

EXECUTION

- Made of tempered steel
- High-temperature brazed at 1,120°C
- Highly wear-resistant carbide studs
- Austempered and surface strengthened
- Easy interchangeability by Screw-together system
- Ratio thread rd 14 2gg
- For hard materials (concrete, granite)

FOR USE IN



APPLICATION





- See product overview p.35
- Adapters with RATIO thread p.34

PACKAGING



Comments

- For a working length of 400 mm and more, pre-drilling must be carried out to a depth of at least 150 mm with a drill bit of the same diameter.
- For a working length of 800 mm and more, pre-drilling must be carried out to a depth of at least 400 mm with a short drill bit of the same diameter.
- Other dimensions on request

 D Ø mm	 D Ø "		 EAN 4016707...	 12345
35,0	1 3/8	1	300011	259 000 035
42,0	1 11/16	1	300035	259 000 042
45,0	1 3/4	1	300042	259 000 045
52,0	2 1/16	1	300066	259 000 052
55,0	2 3/16	1	300073	259 000 055
60,0	2 3/8	1	300080	259 000 060
65,0	2 5/8	1	300097	259 000 065
70,0	2 3/4	1	300103	259 000 070
80,0	3 1/16	1	300110	259 000 080
90,0	3 9/16	1	300127	259 000 090
100,0	3 15/16	1	300134	259 000 100
110,0	4 3/8	1	300141	259 000 110

BREAK-THROUGH CORE DRILL BIT WITH RATIO THREAD

With self-sharpening carbide studs:

- High drilling power due to wear-resistant carbide studs which sharpen automatically during cutting
- Ideal for use in hard, dry concrete, granite and very hard stone

The principle:

- Interchangeability of all components in the drilling system
- Any length of extension is possible due to simply screwing together parts

The advantages:

- Economic drilling in concrete, masonry and lightly reinforced concrete from Ø35 to Ø150mm diameter and to a depth of up to 2 metres
- Above average tool life
- Smooth breakthroughs through concrete and masonry up to large diameters due to practical designs.
- The system can be extended as required by simply screwing together the 300 mm and 450 mm extension pieces. It is recommended to grease the threaded bolts to ensure easy and non-destructive release of the components. We recommend the thread grease for this (Item 259 008 010)

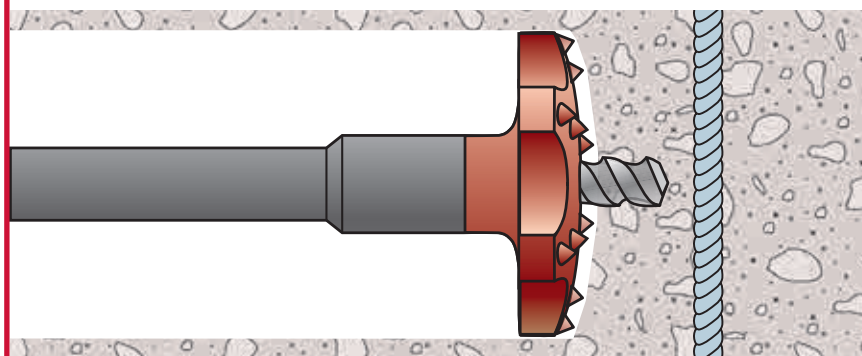

259 HAMMER HOLLOW CORE WITH RATIO THREAD

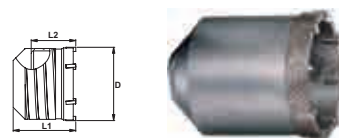

EXECUTION

- Made of tempered steel
- High-temperature vacuum brazed at 1,120°C
- Highly wear-resistant carbide tips
- Hardened and surface strengthened
- 2 stage special high temperature heat treatment
- Easy interchangeability by screw-together system
- Ratio thread rd 14 2gg

FOR USE IN



APPLICATION

- See product overview p.35
- Adapters with RATIO thread p.34

PACKAGING



D Ø mm	D Ø "	L2 mm	L1 mm		EAN 4016707...	 12345
40,0	1 9/16	75	100	1	300523	259 700 040
50,0	2	75	100	1	300462	259 700 050
60,0	2 3/8	75	100	1	300592	259 700 060
65,0	2 5/8	75	100	1	300479	259 700 065
80,0	3 1/8	75	100	1	300486	259 700 080
90,0	3 9/16	75	100	1	300493	259 700 090
100,0	3 15/16	75	100	1	300509	259 700 100
110,0	4 3/8	75	100	1	300547	259 700 110
125,0	5	75	100	1	300608	259 700 125

CUTTING HELIX



D Ø mm	L2 mm	L1 mm			EAN 4016707...	 12345
32,0	80	115	32 - 45 mm	1	343018	259 032 000
47,0	80	115	52 - 60 mm	1	343025	259 047 000
63,0	80	115	65 - 70 mm	1	343032	259 063 000
78,0	80	115	80 - 150 mm	1	343049	259 078 000

EXTENSION WITH RATIO THREADED BOLT



L1 mm		EAN 4016707...	 12345
300	1	300189	259 300 000
450	1	300196	259 450 000

THREADED BOLT WITH RATIO THREAD



L1 mm		EAN 4016707...	 12345
60	1	300219	259 000 001

259 HAMMER HOLLOW CORE WITH RATIO THREAD

EXECUTION

- Made of tempered steel
- High-temperature vacuum brazed at 1,120°C
- Highly wear-resistant carbide tips
- Hardened and surface strengthened
- 2 stage special high temperature heat treatment
- Easy interchangeability by screw-together system
- Ratio thread rd 14 2gg

FOR USE IN



APPLICATION

- See product overview p.35
- Adapters with RATIO thread p.34

PACKAGING



CENTRE DRILL BIT WITH RATIO THREAD



D ø mm	D ø "	L1 mm			EAN 4016707...	12345
12,0	15/32	155	Hammer hollow core	1	300516	259 120 155
16,0	5/8	124	Break through core	1	300226	259 160 124
16,0	5/8	174	Break through core	1	300233	259 160 174

THREAD GREASE 120 GRAMS, WATERPROOF, HEAT RESISTANT



	EAN 4016707...	12345
1	300554	259 008 010

HAMMER HOLLOW CORE WITH RATIO THREAD

- Flexible use with many 259 system components, such as drill adapters, extension pieces etc.
- Extremely solid design for the most demanding applications
- Manufactured of tempered steel which is used, among other things, for crankshafts and drive axles in the automotive industry
- Particularly high impact strength carbide studs which also cut very well
- High-temperature vacuum brazing at 1,120°C
- 2-steps special high temperature treatment

The principle:

- Interchangeability of all components in the drilling system
- Any length of extension is possible due to simply screwing together parts

The advantages:

- Economic drilling in concrete, masonry and lightly reinforced concrete from ø35 to ø150mm diameter and to a depth of up to 2 metres
- Above average tool life
- Smooth breakthroughs through concrete and masonry up to large diameters due to practical designs.
- The system can be extended as required by simply screwing together the 300 mm and 450 mm extension pieces. It is recommended to grease the threaded bolts to ensure easy and non-destructive release of the components. We recommend the thread grease for this (Item 259 008 010).

259 ADAPTERS WITH RATIO THREAD



EXECUTION

- Internal thread RATIO rd 14 2gg

APPLICATION

- For locking of core bits with ratio thread

PACKAGING



DRIVE



SDS-plus
HILTI TE-C

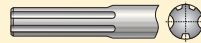

SDS-max
HILTI TE-Y



L1



mm



12345



EAN
4016707...

110

259 170 000

300271

190

259 150 000

300301

400

259 150 400

300615

575

259 150 575

300578

975

259 150 975

300585

259 SYSTEM 259 PRODUCT OVERVIEW

ADAPTER

**EXTENSION WITH
THREADED BOLT**

STEEL HELIX

**CORE DRILL
BIT**

DRILL BIT

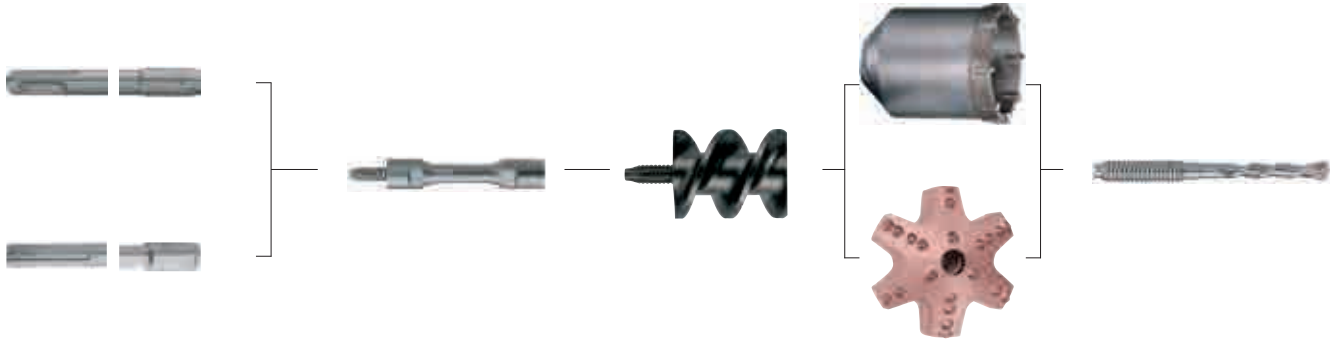

EXAMPLES

Example 1



Example 2



Example 3



extendable to maximum 5 extensions

265 ADAPTERS FOR SDS-PLUS



EXECUTION

- Locking grooves with sliding lock

APPLICATION

- For use with SDS-plus hammer drill bits

PACKAGING



DRIVE 



SDS-top
HILTI TE-T

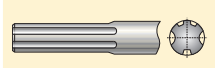

SDS-max
HILTI TE-Y



L1  mm  2345 

225

265 160 000

270314

225

265 150 000

270239

264 SDS-PLUS LOCATING SHANK FOR CHUCKS

SDS-PLUS LOCATING SHANK FOR BITS AND KEILBIT

DRIVE

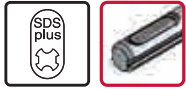

SDS-PLUS LOCATING SHANK FOR CHUCKS



EXECUTION

- 1/2" thread - 20 UNF-2A
- Internal M6-LH thread
- Shank for chuck
- Screw included
- Suitable for hammer drilling machines with SDS-plus fitting



PACKAGING



SDS-PLUS LOCATING SHANK FOR BITS AND KEILBIT



DRIVE

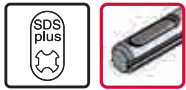

EXECUTION

- Bit holder with SDS-plus fitting
- Made of stainless steel with forged inside hexagon 1/4" bit locking

PACKAGING



GET TO KNOW YOUR TOOLS BETTER:

WATCH THE KEIL PRODUCT VIDEOS

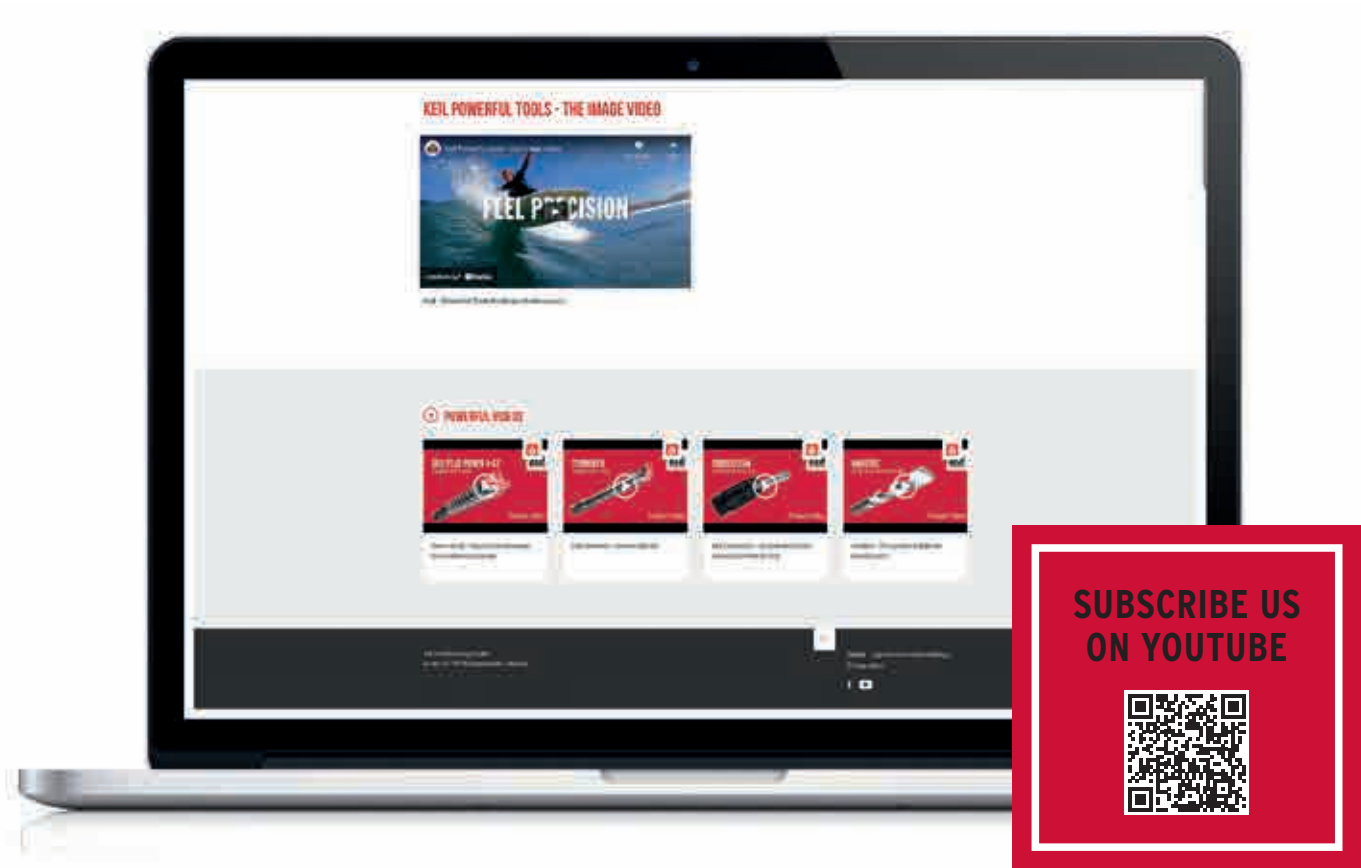

SCAN QR-CODE AND
FIND THE RIGHT TOOL



CHISEL



500 501 Chisel RS self sharpening	41
502-509 Point chisel	42
502-509 Flat chisel	42
502-509 Spade chisel	43
500 503 Hollow chisel	43
500 503 Chisel with channel and glides	44
500 503 Tile chisel	44

CHISEL

Concrete, brick work, asphalt or natural stone - with our percussion drilling tools we always offer the perfect solution - also for the most difficult chisel applications.

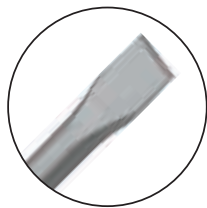

CHISEL

The chisel is made of shot peened and high quality tool steel. The different types are point chisel, flat chisel, spade chisel, hollow chisel, the uni-channel chisel and the tile chisel.

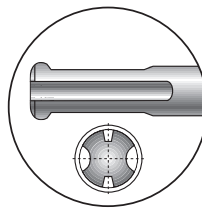

SDS-PLUS DRIVE

The SDS-plus drive is designed for light chisel working with optimum load transmission. The SDS-plus drive is also available as point chisel for drill machines without rotating shutdown.

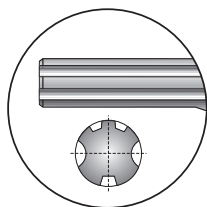

SDS-MAX DRIVE

The SDS-max drive is designed for hard and continuous operation.

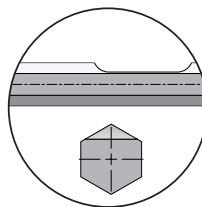

HEXAGONAL DRIVE

The drive is suitable for all percussion hammer with different hexagonal locking.

500 CHISEL RS SDS-PLUS AND SDS-MAX

501 SELF SHARPENING

DRIVE



FOR USE IN

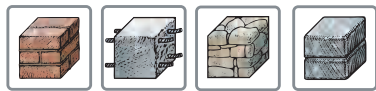

PACKAGING



SPECIALTIES

Advantages:

- Permanent sharper chisels
- Reduced wear
- No need to re-sharpen
- Continual high removal performance
- Economical working
- Long tool life
- High stability by means of technical improvements

Characteristics:

- Innovative geometries which make it easy to penetrate into the material to be removed
 - Point chisel with twisted profile
 - Flat chisel with power ribs and bars
 - Spade and scraping chisel with constantly slim surface and strengthening ribs on the sides
- Shot peened and hardened high quality and wear-resistant tool steel

SDS-PLUS / HILTI TE-C



	L1 mm	B mm	EAN 4016707...	12345
Point chisel	250		916434	500 000 250
Flat chisel	250	20	916458	500 120 250
Spade chisel	250	40	916472	500 240 250
Scraping chisel	250	60	916489	500 260 250

SDS-MAX / HILTI TE-Y





	L1 mm	B mm	EAN 4016707...	12345
Point chisel	400		916441	501 000 400
Flat chisel	400	25	916465	501 125 400
Spade chisel	400	80	916496	501 280 400



SDS-PLUS / HILTI TE-C

- For use in heavy drill and hammer machines
- For light chiselwork at renovation and restoration





SDS-MAX / HILTI TE-Y

- For use in heavy drill and hammer machines
- Suitable for especially heavy and continuous operation
- For mortising and demolition work, breakthroughs, renovation and restoration

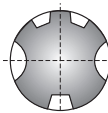

POINT CHISEL

EXECUTION

- Made of high-quality tool steel, shot-peened and hardened

FOR USE IN

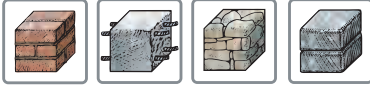

PACKAGING

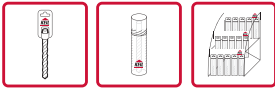

SDS-plus
SDS-max

[161]

DRIVE

SDS-plus HILTI
TE-C without
disabling
of rotation



SW 28

SW 30 Ø 24 x 55 mm



FLAT CHISEL

EXECUTION

- Made of high-quality tool steel, shot-peened and hardened

FOR USE IN

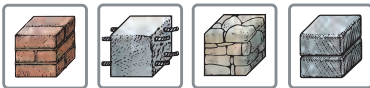

PACKAGING



SDS-plus
SDS-max

[161]

DRIVE

SDS-plus
HILTI TE-C



SW 28

SW 30 Ø 24 x 55 mm



SPADE CHISEL

EXECUTION

- Made of high-quality tool steel, shot-peened and hardened

FOR USE IN

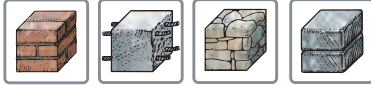

PACKAGING



SDS-plus
SDS-max

[16]

DRIVE



SW 28

SW 30 Ø 24 x 55 mm



HOLLOW CHISEL

EXECUTION

- Made of high-quality tool steel, shot-peened and hardened

FOR USE IN



PACKAGING



SDS-plus
SDS-max

[16]

DRIVE



CHISEL WITH CHANNEL AND GLIDES

EXECUTION

- Made of high-quality tool steel, shot-peened and hardened

DRIVE

FOR USE IN



PACKAGING

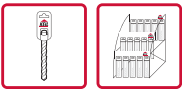

SDS-plus
SDS-max

[161]



TILE CHISEL

EXECUTION

- Made of high-quality tool steel, shot-peened and hardened

DRIVE

FOR USE IN



PACKAGING

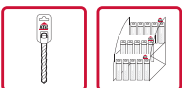

SDS-plus
SDS-max

[161]



STONE AND SPECIAL DRILL BITS

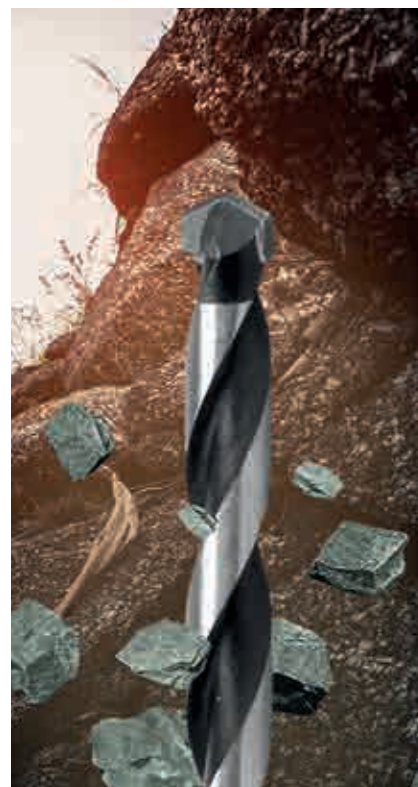

119 219 Universal drill bit GOLDCRAFT	48-49
119 SDS-plus MS5 universal drill bit GOLDCRAFT	50
168 Hard stone drill bit HARDTEC	51
151 Tile / brick drill bit KERAMIK	52
774 Diamond Core Allround	53
786 Tile drill bit KERAMIK diamond - dry drill	54-55
788 Tile drill bit KERAMIK diamond - dry drill M14	54-55
130 Glass drill bit	56
131 Glass drill bit KEILBIT	57
166 Universal drill bit KEILBIT	58
238 Concrete drill bit MS5 TURBOHEAD Xpro	59
258 Concrete drill bit MS5 TURBOKEIL	60
154 204 404 Granite drill bit PRIMUS	61
150 200 400 600 Percussion drill bit KEILER	62-63
190 290 Masonry drill bit OPAL	64
715 Universal hollow core	65
719 Universal hollow core M16 GOLDCRAFT	66
719 Centre drill bit GOLDCRAFT for locating shank M16	67
711 Hollow core M16 complete	68
710 Hollow core M16	69
712 Locating shank M16 hexagon	70
713 Locating shank M16 SDS-Plus	71
715 Centre drill bit for locating shank M16	71
714 Locating shank M16 SDS-PLUS complete	72
800 Quick bit holder for bits and KEILBIT	72

PERCUSSION DRILL BITS

No problem at all. The percussion drill bit easily and precisely manages each challenge.

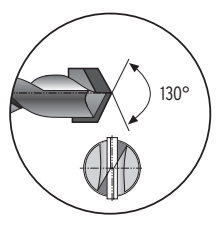

UNIVERSAL DRILL BITS GOLDCRAFT

With the special cutting edge geometry, the diamond ground cutting zone and the carbide plate the GOLDCRAFT is suitable for nearly all materials to be drilled. The very hard tungsten-titanium carbide tip stands for an extremely wear resistant drill bit.

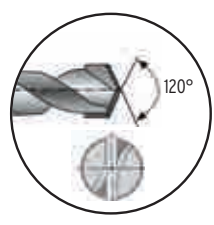

HARD STONE DRILL BIT HARDTEC

Thanks to the high portion of tungsten carbide and its homogeneous fine structured grain the HARDTEC can drill reliable through hardest stone like granite, gneiss, slate and basalt at the recommended 1000 rpm and high contact pressure.

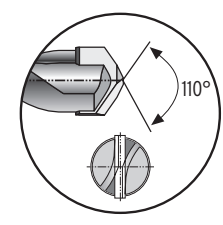

TILE / BRICK DRILL BITS

The high-performance drill bit allows dry drilling in hardest ceramics, stoneware, tiles and hard burnt bricks up to a scratch hardness of 9.

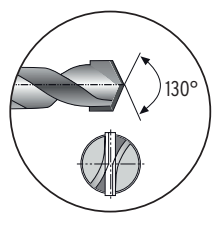

STONE DRILL BIT

The masonry drill has a non-cutting shaped drilling helix, which is also suitable for rotating application into concrete. The material strength is adapted to drill shanks and shaft diameters. Therefore it is appropriate for rotating as well as for percussive application.

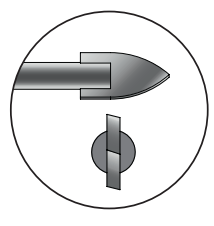

GLASS DRILL BIT

The glass drill bit drills precise and exact holes in sensitive and hard materials. The specially ground cutting edge allows a careful drilling process. The life time of this drill can be considerably prolonged by regrinding.

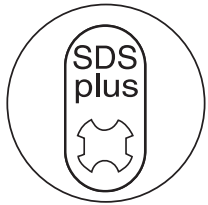

SDS-PLUS LOCKING

The SDS-plus shaft is directly fitting into all hammer drilling machines with SDS-plus and Hilti TE-C chuck.

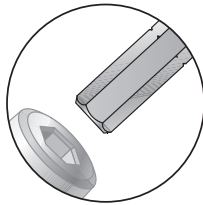

KEILBIT (C 6.3 MM)

This is a different kind of shaft of the KEILBIT with short hexagonal shank and short drill bit.

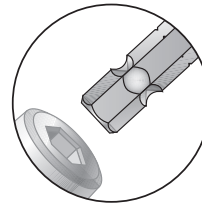

KEILBIT (E 6.3 MM)

Modern cordless screwdrivers are extremely powerful and can definitely be used for drilling. The KEILBIT has specially been invented for the fast and direct application in these machines. No change of machines is necessary anymore. For the various materials we offer different alternatives of the KEILBIT.



ROTASTOP

Optimal anti-twist protection, low frictional loss, high drilling performance. 99 % of the ROTASTOP shape guarantee an optimum transmission of torque. The result: no slipping in the chuck. ROTASTOP allows easy tool changing within seconds

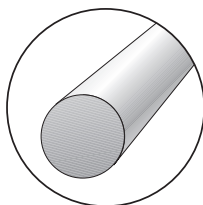

CYLINDRICAL SHAFT

Tools with round shaft are the top selling drilling tools. The round shaft is fitting into all three-jaw chucks and quick change chuck.

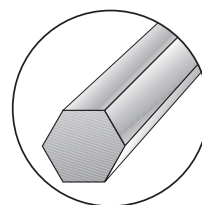

HEXAGONAL SHAFT (10.0 MM)

The hexagonal shank offers a better transmission of rotation especially when working with big diameters and long drill bits.

119 | 219 **UNIVERSAL DRILL BIT GOLDCRAFT****DRIVE****EXECUTION**

Certified product by
Prüfgemeinschaft Mauerbohrer (PGM)

- ISO 5468
- Special cutting edge geometry (see diagram)
- Diamond-ground carbide tip
- Milled flute for optimum removal of drilling dust
- Straight flute entry
- High-temperature brazing at about 1,120°C
- Special cutting helix with micro surface hardness
- Ground surface

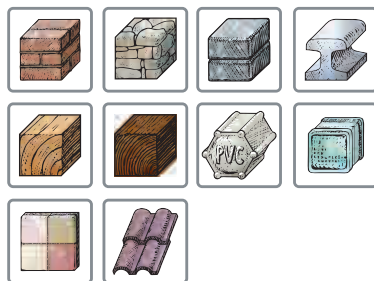
FOR USE IN**APPLICATION**

- In all rotary and percussion drilling machines

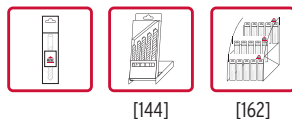
PACKAGING

[144]

[162]

Comments

- Regrinding of the carbide tip becomes necessary during prolonged use
- Higher wear of carbide tip when drilling in abrasive materials
- Only use sharp drill bits for drilling in porcelain, ceramics, glass

**UNIVERSAL DRILL BIT
GOLDCRAFT**

The GOLDCRAFT is suitable for almost all materials to be drilled due to the special cutting edge geometry and the diamond-ground cutting surfaces of the carbide tip.

The very hard tungsten-titanium carbide tip makes the drill bit extremely wear resistant.

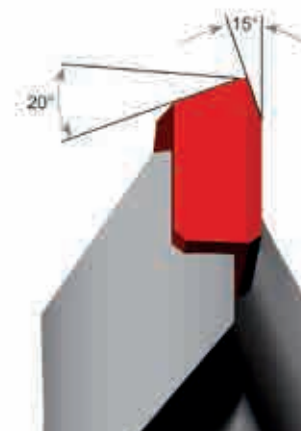

UNIVERSAL DRILL BIT

GUIDE VALUES FOR UNIVERSAL DRILL BITS GOLDCRAFT

Diameter in mm		4 → 16			
Rotations per minute	2350	1500		Soft Wood	
	1880	1030		Ceramics	
	1580	800		Masonry, marble, artificial stone, concrete, granite, tiles, plastic materials, acrylic	
	1120	640		Steel, Cast Steel	
	1700	510		Hard Wood	
	850	410		Glass, Crystal	

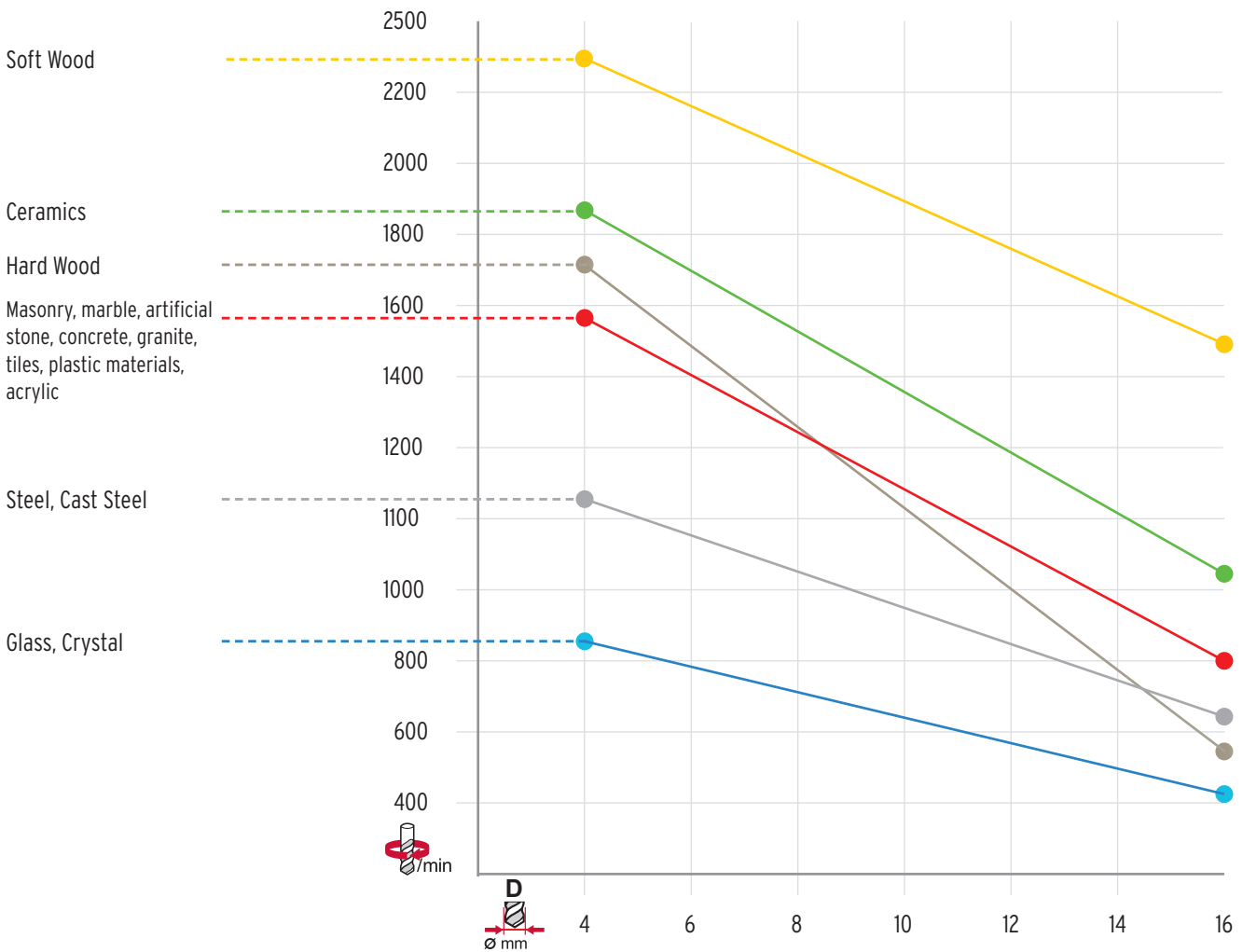

119 SDS-PLUS UNIVERSAL DRILL BIT GOLDCRAFT

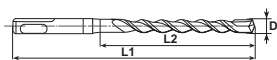

DRIVE

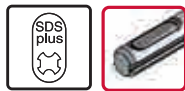

EXECUTION



Certified product by
Prüfungsgemeinschaft Mauerbohrer (PGM)

- ISO 5468
- Special cutting edge geometry (see diagram)
- Diamond-ground carbide tip
- Universal drill bit with MS5 helix
- High-temperature brazing at about 1,120°C
- Special cutting helix with micro surface hardness
- Ground surface

D Ø mm	D Ø "	L2 mm	L1 mm		EAN 4016707	12345
5,0	3/16	50	110	1	213090	119 255 010
6,0	15/64	50	110	1	213106	119 255 011
6,0	15/64	100	160	1	213014	119 255 001
8,0	5/16	50	110	1	213113	119 255 012
8,0	5/16	100	160	1	213021	119 255 002
8,0	5/16	150	210	1	213038	119 255 003
10,0	3/8	100	160	1	213045	119 255 004
10,0	3/8	200	260	1	213052	119 255 005
12,0	15/32	100	165	1	213069	119 255 006
12,0	15/32	200	260	1	213076	119 255 007
14,0	9/16	200	265	1	213083	119 255 008

FOR USE IN

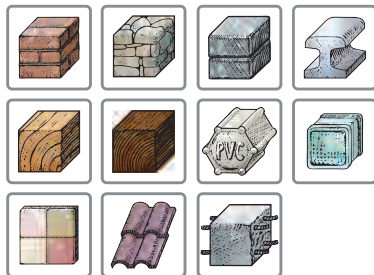

APPLICATION

- Fits directly into all hammer drilling machines with SDS-plus and HILTI TE-C drive
- Adapters for SDS-plus [36]

PACKAGING

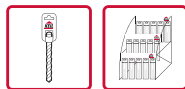

[162]

Comments

- Regrinding of the carbide tip becomes necessary during prolonged use
- Higher wear of carbide tip when drilling in abrasive materials
- Only use sharp drill bits for drilling in porcelain, ceramics, glass

SDS-PLUS MS 5 UNIVERSAL DRILL BIT GOLDCRAFT

The GOLDCRAFT is suitable for almost all materials to be drilled due to the special cutting edge geometry and the diamond-ground cutting surfaces of the carbide tip.

The very hard tungsten-titanium carbide tip makes the drill bit extremely wear resistant.

MS5 spiral for ergonomic and ecological work flow:

- High drilling speed
- Fast transport of drilling dust
- High grade of stiffness and long service life
- High resistance against Breakage

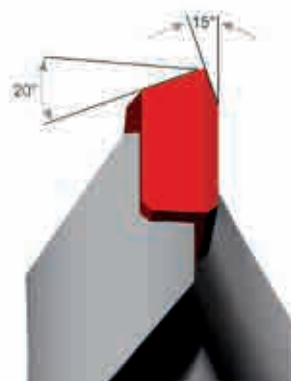

168 HARDTEC HARD STONE DRILL BIT



DRIVE



D Ø mm	D Ø 31	L2 mm	L1 mm	d Ø mm		EAN 4016707...	 12345
4,0	5/32	40	75	4	20	915772	168 000 040
5,0	3/16	50	85	5	20	915789	168 000 050
6,0	15/64	60	100	6	20	915796	168 000 060
8,0	5/16	75	120	8	20	915802	168 000 080
10,0	3/8	75	120	10	20	915857	168 000 100

EXECUTION



Certified product by
Prüfgemeinschaft Mauerbohrer (PGM)

- ISO 5468
- Diamond-ground carbide tip
- Universal drill bit with MS5 helix
- High-temperature brazing at about 1,120°C
- Special cutting helix with micro surface hardness
- Ground surface

FOR USE IN

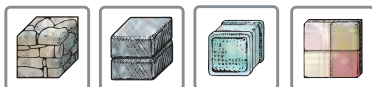

APPLICATION

- In all rotary and percussion drilling machines
- Only for rotary use
- High contact pressure
- Rotation speed approx. 1000 rpm

PACKAGING

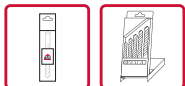

[144]

SPECIAL FEATURES

Special carbide tip:

- High portion of tungsten carbide
- Homogenous fine structured grain
- Special cutting edge of 120°
- Precise diamond grinding

Materials:

- Expert for granite, gneissic rock, slate, basalt
- Specially suitable for hard ceramic tiles, porcelain and other hard materials

Advantages:

- Wear resistant carbide drill bit with long life time
- High drilling speed
- The drill bit can be resharpened with a diamond- or silicon carbide grinding wheel
- Very long service life



151 TILE/BRICK DRILL BIT KERAMIK WITH TSM CARBIDE TIP

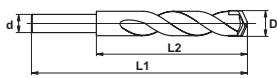

DRIVE



EXECUTION

- ISO 5468
- Milled flute for optimum removal of drilling dust
- Straight flute entry
- Tungsten-titanium TSM carbide tip
- High-temperature brazing at about 1,120°C
- Burnished surface
- Up to 12 mm Ø with ROTASTOP shank

D Ø mm	D Ø 31	L2 mm	L1 mm	d Ø mm			
4,0	5/32	40	75	3,6	20	510106	151 018 040
5,0	3/16	50	85	4,6	20	510113	151 018 050
5,5	7/32	50	85	5,1	20	904875	151 018 055
6,0	15/64	60	100	5,6	20	510120	151 018 060
6,5	1/4	60	100	6,1	20	904882	151 018 065
8,0	5/16	80	120	7,1	20	510137	151 018 080
10,0	3/8	80	120	8,7	20	510144	151 018 100
12,0	15/32	90	150	10,0	10	510151	151 018 120
14,0	9/16	90	150	10,0	10	510090	151 017 140

FOR USE IN



DRILLING INFORMATION

- A recommended speed of 600 to 1,200 rpm and sufficient contact pressure, which is always required for the exclusively rotary drilling of hard materials, are the prerequisites for good drilling progress and a long life of the drill tip.
- When used with rechargeable drilling machines the drill bit provides noticeably faster drilling than comparable rotary drill bits.
- We recommend to affix adhesive tape at the place of drilling.

APPLICATION

- In all rotary and percussion drilling machines
- High contact pressure
- 20 seconds cooling time
- Only for rotary use
- In materials up to scratch hardness of 9
- Drilling process and tool life can be increased by cooling with water

PACKAGING



[144]

[144]

[162]

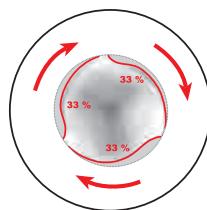

ROTASTOP

- The polygonal shape of the ROTASTOP section on the outside of the drill bit reduces surface contact to 3 points which leads to a reduction in the frictional resistance and thus to a considerably higher rate of work with noticeably improved performance of the drill bit.
- ROTASTOP allows easy tool changing within seconds and longer service lives for the tools.
- Optimal torsional rigidity | Low frictional losses | High drilling performance

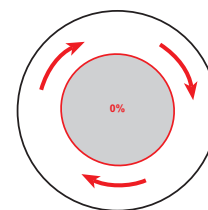

PRODUKT INFORMATION ROTASTOP

- Strength from the contour. The new performance shank for optimum torque transmission
- An unmatched 99 % of the contour of the ROTASTOP tool bit ensure optimum transmission of the torque, as ROTASTOP practically chucks itself automatically by means of the rising contours.
- The result: No slipping in the chuck and precise results when processing material.

774 DIAMOND CORE ALLROUND



EXECUTION

- Fast feed speed thanks to segmented cutting edge
- Universally deployable thanks to laser-welded diamond segments
- Self-sharpening for high cutting performance and long service life

FOR USE IN

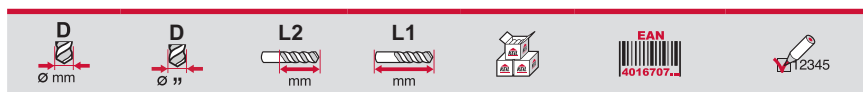
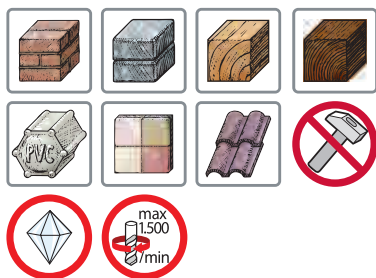

Diamond core allround M16 Keil standard

5	68	65	95	10	924453	774 000 068
5	82	65	95	10	924460	774 000 082

Diamond core allround M16 complete HEXAGON Keil standard

5	68	65	95	10	924477	774 712 068
5	82	65	95	10	924484	774 712 082

Diamond core allround complete SDS-Plus Keil standard

5,5	68	65	95	10	924491	774 713 068
5,5	82	65	95	10	924507	774 713 082



SDS-PLUS



HEXAGON



CENTER DRILL BIT

786 TILE DRILL BIT/KERAMIK DIAMOND - DRY DRILL

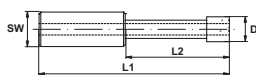

DRIVE



EXECUTION

- Vacuum-soldered diamonds
- Burnished surface
- Hollow section completely filled with cooling liquid (up to $\varnothing 15\text{mm}$)

FOR USE IN



- In all rotary and percussion drilling machines
- Recommended cooling time 10 seconds
- For rotary use only
- In materials up to scratch hardness 9
- Dry drilling, no water necessary
- Long tool life with water supply

PACKAGING



[144]

786 TILE DRILL BIT/
KERAMIK DIAMOND

D \varnothing mm	L1 mm	SW mm	min		EAN 4016707...	12345
5,0	67	9,00	2.000	1	905735	786 090 050
6,0	67	9,00	2.000	1	905742	786 090 060
8,0	80	9,00	1.800	1	905759	786 090 080
10,0	80	9,00	1.600	1	905766	786 090 100
12,0	80	9,00	1.400	1	905773	786 090 120
15,0	80	9,00	1.400	1	905780	786 090 150
20,0	70	9,00	1.400	1	905797	786 090 200
25,0	70	9,00	1.400	1	905803	786 090 250
30,0	70	9,00	1.200	1	905810	786 090 300
35,0	70	9,00	1.200	1	905827	786 090 350
68,0	70	9,00	800	1	905865	786 090 680

788 TILE DRILL BIT KERAMIK
DIAMOND WITH INTERNAL
SCREW THREAD M14

D \varnothing mm	L1 mm	SW mm	min		EAN 4016707...	12345
5,0	62	M14	10.000	1	915673	788 140 050
6,0	62	M14	10.000	1	915680	788 140 060
8,0	62	M14	10.000	1	915697	788 140 080
10,0	62	M14	10.000	1	915703	788 140 100
12,0	62	M14	10.000	1	915710	788 140 120
15,0	62	M14	10.000	1	915727	788 140 150
20,0	60	M14	10.000	1	915734	788 140 200
25,0	60	M14	10.000	1	915741	788 140 250
30,0	60	M14	10.000	1	915758	788 140 300
35,0	60	M14	10.000	1	915765	788 140 350

ACCESSORIES FOR
TILE DRILL BIT
KERAMIK DIAMOND

No		EAN 4016707...	12345
1	1	580086	786 100 000
2	1	580093	786 100 002
3	1	580130	786 200 000
4	1	580123	786 200 001

TILE DRILL BIT KERAMIK DIAMOND - DRY DRILL

Dry drilling in hardest materials, hard stoneware tiles, porcelain, bricks, glass, marble, granite and slate.

ADVANTAGES:

- Fast drill progress
- Long tool life
- Clean cutting edge
- Dry drilling



For the complete installation of a bathroom a high number of bore holes in hard material is necessary. These materials become more and more demanding where the appropriate drilling tool is concerned. Nowadays not only plain tiles are used but hard stoneware like porcelain quality 5, marble, granite, hard ceramics as well as hardened tiles.

The Tile drill bit KERAMIK diamond is the ideal drilling tool to set safely and effectively a clean and precise hole. The advantage of these drill bits are the long durability and the speediness of the drilling process.

The drill bits are completed by professional accessories which guarantee that the drilling will be set on the exact place where it was planned. The two former plates are secure and foot-sure by the use of big vacuum suction stands. So they give the drill bit a secure hold for a precise drill.

As additional possibility besides water supply herewith Keil offers a complete system. The add-on water prolongs tool life, but is not necessary in principle.

Recommended rotation speed Tile drill bit / KERAMIK diamond 786 - dry drill

D Ø mm	/min
5,0	2000
6,0	2000
8,0	1800
10,0	1600
12,0	1400
15,0	1400
20,0	1400
25,0	1400
30,0	1200
35,0	1200
68,0	800

PILOT DRILLING WITHOUT ANY FACILITIES:



130 GLASS DRILL BIT

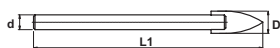

DRIVE



D Ø mm	D Ø "	L1 mm	d Ø mm		EAN 4016707	
3,0	1/8	58	3,0	20	010019	130 000 030
4,0	5/32	58	3,5	20	010026	130 000 040
5,0	3/16	58	4,0	20	010033	130 000 050
5,5	7/32	58	4,0	20	010200	130 000 055
6,0	15/64	58	5,0	20	010040	130 000 060
7,0	9/32	78	5,0	20	010057	130 000 070
8,0	5/16	78	6,0	20	010064	130 000 080
9,0	11/32	98	6,0	20	010071	130 000 090
10,0	3/8	98	6,0	20	010088	130 000 100
12,0	15/32	98	8,0	20	010095	130 000 120

EXECUTION

- Specially ground carbide tip
- Zinc-plated surface
- Thinned cross cutting edges provide precise drilling of pilot holes

FOR USE IN



APPLICATION

- In all rotary and percussion drilling machines
- In machines for mechanical processing
- Only for rotary use
- In materials up to scratch hardness of 8

PACKAGING



[162]

Comments

- Set a low speed
- Cool sufficiently with water, turpentine, vinegar or paraffin
- Regrind frequently when drilling in hard materials

GLASS DRILL BIT

The classic drilling tool for glass machining. Drills precise and exact holes in sensitive and hard materials. The specially ground cutting edges allow a careful drilling process. The tool life can be considerably prolonged by means of regrinding. During drilling process sufficient cooling and slow rotation speed is needed.



131 GLASS DRILL BIT KEILBIT

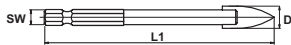

DRIVE



D Ø mm	D Ø "	L1 mm	SW mm		EAN 4016707...	 12345
3,0	1/8	75	6,35	20	010224	131 000 300
4,0	5/32	75	6,35	20	010231	131 000 400
5,0	3/16	75	6,35	20	010248	131 000 500
6,0	15/64	75	6,35	20	010255	131 000 600
8,0	5/16	85	6,35	20	010262	131 000 800
10,0	3/8	85	6,35	20	010279	131 001 000

EXECUTION

- Specially ground carbide tip
- Grey surface
- Thinned cross cutting edges provide precise drilling of pilot holes
- 1/4" bit drive DIN 3126 - E 6.3

FOR USE IN



APPLICATION

- In all rotary and percussion drilling machines
- In machines for mechanical processing
- Only for rotary use
- In materials up to scratch hardness of 8
- In all drilling machines, cordless screw drivers and bit holders with 1/4" drill shank
- SDS-plus locating shank for Bits and KEILBIT [37]
- Quick bit holder for bits and KEILBIT [72]

PACKAGING



Comments

- Set a low speed
- Cool sufficiently with water, turpentine, vinegar or paraffin
- Regrind frequently when drilling in hard materials

GLASS DRILL BIT KEILBIT

- Modern cordless screw drivers are extremely efficient and can also be used for drilling without any problems. The KEILBIT was particularly developed for quick direct application in these machines.
- Machine changing is not necessary anymore.
- For drilling other materials we offer various types of KEILBIT.

166 UNIVERSAL DRILL BIT KEILBIT



DRIVE



D Ø mm	D Ø "	L2 mm	L1 mm	SW mm		 EAN 4016707...	 12345
3,0	1/8	35	75	6,35	20	220098	166 000 030
4,0	5/32	45	85	6,35	20	220012	166 000 040
5,0	3/16	50	95	6,35	20	220029	166 000 050
6,0	15/64	60	100	6,35	20	220036	166 000 060
8,0	5/16	70	120	6,35	20	220043	166 000 080
10,0	3/8	70	120	6,35	20	220050	166 000 100
12,0	15/32	85	140	6,35	10	220067	166 000 120

EXECUTION

- Asymmetric spiral shape
- Milled flute for optimum removal of drilling dust
- Straight flute entry
- High-temperature brazing at about 1.120°C
- Grey blasted surface
- Euro standard carbide tip
- 1/4" bit drive DIN 3126 - E 6.3

FOR USE IN

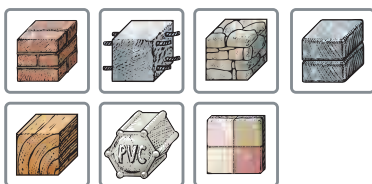

UNIVERSAL BIT DRILL KEILBIT

- Modern cordless screw drivers are extremely efficient and can also be used for drilling without any problems. The KEILBIT was particularly developed for quick direct application in these machines.
- Machine changing is not necessary anymore.
- For drilling other materials we offer various types of KEILBIT.

APPLICATION

- In all rotary and percussion drilling machines
- In machines for mechanical processing
- Only for rotary use
- In all drilling machines, cordless screw drivers and bit holders with 1/4" drill shank
- SDS-plus locating shank for Bits and KEILBIT
- Quick bit holder for bits and KEILBIT

PACKAGING



[145]

238 CONCRETE DRILL BIT MS5 TURBOHEAD XPRO

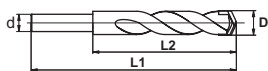

DRIVE



EXECUTION



- Hammer-resistant percussion drill bit with round shank
- ISO 5468
- MS5 spiral with strengthened core
- Made of tempered steel, shot-peened and intermediate level hardened
- TURBOHEAD Xpro with 4 cutting edges concept and centering tip
- High-temperature brazing at about 1.120° C

FOR USE IN



APPLICATION

- In all rotating and percussion drilling machines as well as hammer drills with three jaw chuck
- For use in armed concrete
- For drilling plug holes
- Particularly suitable for fastenings

PACKAGING

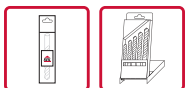

[145]

Comments

- High drilling speed
- Long tool life
- Other dimensions on request

D Ø mm	D Ø "	L2 mm	L1 mm	d Ø mm	Box	EAN 4016707...	12345
5,0	3/16	50	85	4,6	20	912689	238 000 050
6,0	15/64	60	100	5,6	20	912696	238 000 060
8,0	5/16	75	120	7,3	20	912702	238 000 080
10,0	3/8	75	120	9,4	20	912719	238 000 100
12,0	15/32	100	160	10,0	10	912726	238 000 120
14,0	9/16	100	160	10,0	10	912733	238 000 140

CONCRETE DRILL BIT MS5 TURBOHEAD XPRO

The hammer-resistant percussion drill bit with round shank and 4 cutting edges concept:

- Precise and simple pilot drilling
- Very fast drilling progress
- Extremely long service life

Features:

- Full carbide head
- Centering tip
- Better performance in armed concrete
- Drills exact round holes

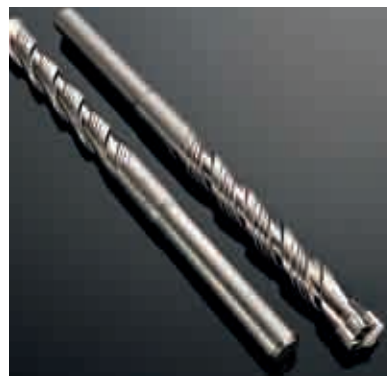

MS5 spiral for ergonomic and ecological work flow:

- High drilling speed
- Fast transport of drilling dust
- High grade of stiffness and long service life
- High resistance against breakage

258 CONCRETE DRILL BIT MS5 TURBOKEIL

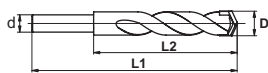

DRIVE



EXECUTION



- ISO 5468
- TURBOKEIL carbide plate with centring tip
- MS5 flute
- Made of chrome-nickel-molybdenum steel, shot-peened and intermediate level hardened
- Straight flute entry
- High-temperature brazing at about 1.120°C
- Grey blasted surface

FOR USE IN



APPLICATION

- In all rotating and percussion drilling machines as well as hammer drills with three jaw chuck
- For drilling plug holes
- Particularly suitable for fastenings

PACKAGING



[145]

[162]

D ø mm	D ø "	L2 mm	L1 mm	d ø mm			
3,0	1/8	40	70	2,8	20	290145	258 000 030
4,0	5/32	40	75	3,6	20	290015	258 000 040
5,0	3/16	50	85	4,6	20	290022	258 000 050
6,0	15/64	60	100	5,6	20	290039	258 000 060
7,0	9/32	60	100	6,6	20	290046	258 000 070
8,0	5/16	75	120	7,3	20	290053	258 000 080
9,0	11/32	75	120	7,3	20	290060	258 000 090
10,0	3/8	75	120	9,4	20	290077	258 000 100
12,0	15/32	100	150	10,0	10	290084	258 000 120
14,0	9/16	100	150	10,0	10	290091	258 000 140
16,0	5/8	100	150	10,0	10	290107	258 000 160

CONCRETE DRILL BIT MS5 TURBOKEIL

The hammer drill bit with round shank:

- Simple precise drilling of pilot holes
- Considerably faster drilling progress
- Significantly longer life

Features:

- Centring tip
- Patented MS5 flute (see p. 19)
- Larger cutting angle
- Strengthened carbide tip
- Harder carbide quality
- Cleaner drilling holes

MS5 spiral for ergonomic and ecological work flow:

- High drilling speed
- Fast transport of drilling dust
- High grade of stiffness and long service life
- High resistance against breakage

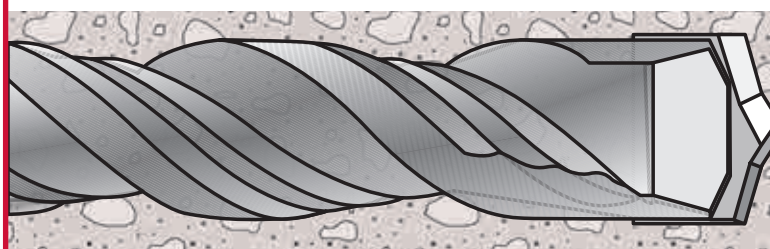

154 | 204 | 404 GRANITE DRILL BIT PRIMUS

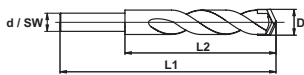

DRIVE

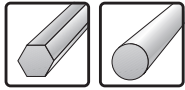

EXECUTION



- ISO 5468
- Straight flute entry
- Milled flute for optimum removal of drilling dust
- High-temperature brazing at about 1.120°C
- Burnished and ground surface

FOR USE IN

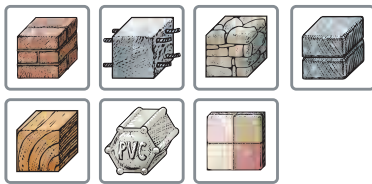

APPLICATION

- In all rotary and percussion drilling machines
- For drilling plug holes
- Particularly suitable for fastenings

PACKAGING



[145]

[163]

Comments

- SW = Hexagonal clamping shank with 45 mm length / wrench size

D Ø mm	D Ø "	L2 mm	L1 mm	SW mm	d Ø mm		EAN 4016707		12345
3,0	1/8	40	70		2,8	20	190018		154 000 030
3,5	9/64	40	70		3,2	20	190209		154 000 035
4,0	5/32	40	75		3,6	20	190025		154 000 040
4,5	11/64	50	85		4,1	20	190193		154 000 045
5,0	3/16	50	85		4,6	20	190032		154 000 050
5,0	3/16	110	150		4,6	10	192005		204 000 050
5,5	7/32	50	85		5,1	20	190049		154 000 055
5,5	7/32	110	150		5,1	10	192074		204 000 055
6,0	15/64	60	100		5,6	20	190056		154 000 060
6,0	15/64	110	150		5,6	10	192012		204 000 060
6,5	1/4	60	100		6,1	20	190063		154 000 065
6,5	1/4	110	150		6,1	10	192029		204 000 065
7,0	9/32	60	100		6,6	20	190070		154 000 070
8,0	5/16	80	120		7,1	20	190087		154 000 080
8,0	5/16	135	200		7,3	10	192036		204 000 080
8,0	5/16	350	400		7,3	1	194016		404 000 080
9,0	11/32	80	120		8,1	20	190094		154 000 090
10,0	3/8	80	120		8,7	20	190100		154 000 100
10,0	3/8	135	200		8,7	10	192043		204 000 100
10,0	3/8	350	400		9,3	1	194023		404 000 100
11,0	7/16	90	150		10,0	10	190186		154 000 110
12,0	15/32	90	150		10,0	10	190117		154 000 120
12,0	15/32	135	200		10,0	10	192050		204 000 120
12,0	15/32	350	400	10,00		1	194030		404 000 120
13,0	1/2	90	150		10,0	10	190124		154 000 130
14,0	9/16	90	150		10,0	10	190131		154 000 140
14,0	9/16	350	400	10,00		1	194054		404 000 140
15,0	19/32	90	150		10,0	10	190148		154 000 150
16,0	5/8	90	150		10,0	10	190155		154 000 160
16,0	5/8	350	400	10,00		1	194061		404 000 160
18,0	11/16	100	160		10,0	5	190162		154 000 180
20,0	3/4	100	160		13,0	5	190179		154 000 200

150 | 200 | 400 | 600 PERCUSSION DRILL BIT KEILER

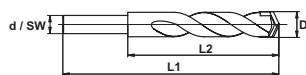

DRIVE

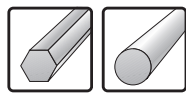

EXECUTION



- ISO 5468
- Straight flute entry
- Milled flute for optimum removal of drilling dust
- High-temperature brazing at about 1,120°C
- Grey blasted surface
- Euro standard carbide tip

FOR USE IN



APPLICATION

- In all rotary and percussion drilling machines
- For drilling plug holes
- Particularly suitable for fastenings

PACKAGING



[145]

[163]

Comments

- SW = Hexagonal clamping shank with 45 mm length / wrench size

D Ø mm	D Ø "	L2 mm	L1 mm	SW mm	d Ø mm		EAN 4016707...	
3,0	1/8	40	70		2,8	20	200014	150 000 030
3,5	9/64	40	70		3,2	20	200021	150 000 035
4,0	5/32	40	75		3,6	20	200038	150 000 040
4,5	11/64	50	85		4,1	20	200045	150 000 045
5,0	3/16	50	85		4,6	20	200052	150 000 050
5,0	3/16	110	150		4,6	10	203015	200 000 050
5,5	7/32	50	85		5,1	20	200069	150 000 055
6,0	15/64	60	100		5,6	20	200076	150 000 060
6,0	15/64	110	150		5,6	10	203039	200 000 060
6,0	15/64	135	200		5,6	10	203138	200 060 200
6,0	15/64	350	400		5,6	1	180019	400 000 060
6,5	1/4	60	100		6,1	20	200083	150 000 065
6,5	1/4	110	150		6,1	10	203046	200 000 065
7,0	9/32	60	100		6,6	20	200090	150 000 070
7,0	9/32	110	150		6,6	10	203053	200 000 070
8,0	5/16	80	120		7,1	20	200106	150 000 080
8,0	5/16	135	200		7,3	10	203060	200 000 080
8,0	5/16	350	400		7,3	1	180033	400 000 080
8,0	5/16	550	600		7,3	1	180170	600 000 080
8,5	21/64	80	120		7,1	20	200113	150 000 085
9,0	11/32	80	120		8,1	20	200120	150 000 090
10,0	3/8	80	120		8,7	20	200137	150 000 100
10,0	3/8	135	200		8,7	10	203077	200 000 100
10,0	3/8	350	400		9,3	1	180040	400 000 100
10,0	3/8	550	600		9,3	1	180187	600 000 100
11,0	7/16	90	150		10,0	10	200144	150 000 110
12,0	15/32	90	150		10,0	10	200151	150 000 120
12,0	15/32	135	200		10,0	10	203084	200 000 120
12,0	15/32	350	400	10,00		1	180057	400 000 120
12,0	15/32	550	600	10,00		1	180194	600 000 120
13,0	1/2	90	150		10,0	10	200168	150 000 130
14,0	9/16	90	150		10,0	10	200175	150 000 140
14,0	9/16	135	200		10,0	10	203091	200 000 140
14,0	9/16	350	400	10,00		1	180071	400 000 140
14,0	9/16	550	600	10,00		1	180200	600 000 140
15,0	19/32	90	150		10,0	10	200182	150 000 150
16,0	5/8	90	150		10,0	10	200199	150 000 160
16,0	5/8	135	200		10,0	10	203107	200 000 160
16,0	5/8	350	400	10,00		1	180088	400 000 160
16,0	5/8	550	600	10,00		1	180217	600 000 160
18,0	11/16	100	160		10,0	5	200205	150 000 180
18,0	11/16	350	400	10,00		1	180095	400 000 180
18,0	11/16	550	600	10,00		1	180224	600 000 180
20,0	3/4	100	160		13,0	5	200212	150 000 200
20,0	3/4	350	400	12,00		1	180101	400 000 200
20,0	3/4	550	600	12,00		1	180231	600 000 200

150 | 200 | 400 | 600 PERCUSSION DRILL BIT KEILER

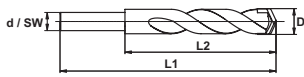

DRIVE

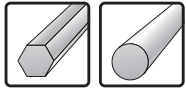

EXECUTION



- ISO 5468
- Straight flute entry
- Milled flute for optimum removal of drilling dust
- High-temperature brazing at about 1,120°C
- Grey blasted surface
- Euro standard carbide tip

FOR USE IN



APPLICATION

- In all rotary and percussion drilling machines
- For drilling plug holes
- Particularly suitable for fastenings

PACKAGING



[145]

[163]

Comments

- SW = Hexagonal clamping shank with 45 mm length / wrench size

D Ø mm	D "	L2 mm	L1 mm	SW mm	d Ø mm	Icon	EAN 4016707	Icon	12345
22,0	7/8	100	160		13,0	5	200229		150 000 220
22,0	7/8	350	400	12,00		1	180118		400 000 220
22,0	7/8	550	600	12,00		1	180248		600 000 220
25,0	1	100	160		13,0	5	200236		150 000 250
25,0	1	350	400	12,00		1	180125		400 000 250
25,0	1	550	600	12,00		1	180255		600 000 250

190 | 290 MASONRY DRILL BIT OPAL

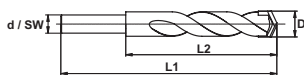

DRIVE



EXECUTION

- ISO 5468
- Non-cutting flute
- High-temperature brazing
- Zinc-plated surface
- Euro standard carbide tip

FOR USE IN



APPLICATION

- In allen Dreh- und Schlagbohrmaschinen

PACKAGING

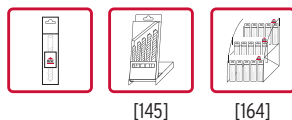

[145]

[164]

D Ø mm	D Ø "	L2 mm	L1 mm	d Ø mm	Icon	EAN 4016707...	Icon 12345
3,0	1/8	40	70	2,8	20	170195	190 000 030
3,5	9/64	40	70	3,2	20	170171	190 000 035
4,0	5/32	40	75	3,2	20	170010	190 000 040
5,0	3/16	50	85	3,8	20	170027	190 000 050
5,0	3/16	110	150	3,8	10	172083	290 000 050
5,5	7/32	50	85	4,4	20	170034	190 000 055
6,0	15/64	60	100	4,7	20	170041	190 000 060
6,0	15/64	110	150	4,7	10	172014	290 000 060
7,0	9/32	60	100	5,4	20	170065	190 000 070
7,0	9/32	110	150	5,4	10	172106	290 000 070
8,0	5/16	80	120	6,4	20	170072	190 000 080
8,0	5/16	135	200	6,4	10	172038	290 000 080
9,0	11/32	80	120	7,1	20	170089	190 000 090
10,0	3/8	80	120	7,8	20	170096	190 000 100
10,0	3/8	135	200	7,8	10	172045	290 000 100
11,0	7/16	90	150	8,5	10	170102	190 000 110
12,0	15/32	90	150	8,5	10	170119	190 000 120
12,0	15/32	135	200	8,5	10	172052	290 000 120
13,0	1/2	90	150	10,0	10	170126	190 000 130
14,0	9/16	90	150	10,0	10	170133	190 000 140
14,0	9/16	135	200	10,0	10	172069	290 000 140
16,0	5/8	90	150	10,0	10	170140	190 000 160
16,0	5/8	135	200	10,0	10	172076	290 000 160
20,0	3/4	100	160	13,0	5	170157	190 000 200

MASONRY DRILL BIT OPAL

- Non-cutting shaped drilling spiral also applicable for the rotary use in concrete
- Made of quenched and subsequently drawn steel according to DIN / EN 10083/2
- The hardness respectively the material consistence is adjusted to the application and the different shank diameter. This is the reason why it is best for the use in all rotary and percussion drilling machines
- Very long tool life

715 UNIVERSAL HOLLOW CORE



DRIVE



EXECUTION

- Tungsten-carbide coated

FOR USE IN

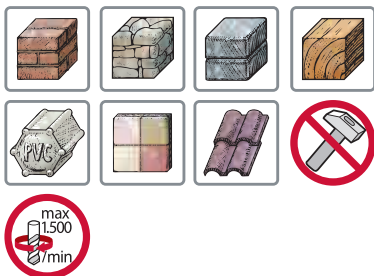

D Ø mm			EAN 4016707...	12345
33,0	3	1	250026	715 000 033
53,0	2	1	250033	715 000 053
67,0	1	1	250040	715 000 067
73,0	1, 2	1	250057	715 000 073
83,0	2	1	250064	715 000 083

LOCATING PLATE FOR UNIVERSAL HOLLOW CORE



	EAN 4016707...	12345
1	250071	715 000 090

APPLICATION

- Only for rotary use
- Bayonet lock

PACKAGING



[144]

Comments

- 3 = Conduits
- 2 = Holes for pipes
- 1 = Sockets

CENTRE DRILL BIT FOR UNIVERSAL HOLLOW CORE



D Ø mm	D Ø "	L1 mm		EAN 4016707...	12345
9,0	11/32	140	1	250095	715 090 140

UNIVERSAL HOLLOW CORE

- The cutting edges of all universal hollow cores are tungsten carbide coated. These carbide cutters which are attached with a high-temperature process ensure economic drilling in materials such as masonry, tiles, brick, breeze block and plasterboard.
- The fast replacement of hollow cores due to the simple bayonet lock and the light-weight design make things easy for the user.
- Can be used for sockets, holes for pipes, junction lines, conduits etc.

Safety Notes:

- Maximum speed in manual drilling machines 1,500 rpm
- Goggles must be worn

719 UNIVERSAL HOLE SAW M16 GOLDCRAFT

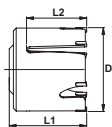

EXECUTION

- With internal M 16 thread
- Grey blasted and rust protected
- 3 carbide cutters up to 55 mm Ø
- 5 carbide cutters up to 90 mm Ø
- 6 carbide cutters up to 105 mm Ø

FOR USE IN

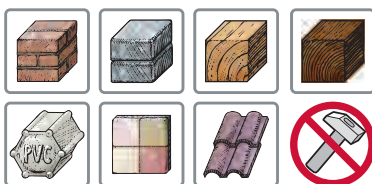

D Ø mm	L2 mm	L1 mm			EAN 4016707...	12345
25,0	65	100	1	1	240010	719 000 025
35,0	65	100	1, 2, 3	1	240034	719 000 035
40,0	65	100	4, 5, 3	1	240041	719 000 040
50,0	65	100	4, 5, 3	1	240065	719 000 050
60,0	65	100	7	1	240096	719 000 060
68,0	65	100	9	1	240126	719 000 068
74,0	65	100	10	1	240133	719 000 074
80,0	65	100	11, 12	1	240140	719 000 080
105,0	65	100	13	1	240164	719 000 105

APPLICATION

- Locating shank M16 for SDS-plus [71]
- Locating shank M16 hexagon [70]
- Centre drill bit GOLDCRAFT for locating shank M16 [67]

PACKAGING



Comments

- Other dimensions on request
- 1 = Sanitary and heating pipes
- 2 = Junction boxes
- 3 = Halogen spot lamps
- 4 = Sanitary waste pipes
- 5 = Water and heating pipes with insulation
- 6 = Recessed lights
- 7 = Case bushings
- 8 = Switch sockets
- 9 = Cavity wall sockets
- 10 = Cavity wall junction boxes
- 11 = Junction boxes
- 12 = Bushing covers
- 13 = Vent pipes

UNIVERSAL HOLE SAW M16 GOLDCRAFT

- For drilling in various materials: various types of masonry, lightweight construction materials, plastics, solid wood, plastic coated wood etc.
- For different application in interior fittings, for electricians, heating fitter, plumber etc. Quality and practical applications for professionals and do-it-yourselfers
- Can be used in all SDS-plus hammer drilling machines or all rotary and percussion drilling machines depending on the locating shank used
- Available in a wide range of dimensions for standard and special applications





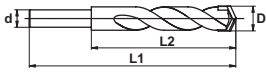



719 CENTRE DRILL BIT GOLDCRAFT FOR LOCATING SHANK M16



DRIVE



 D ø mm	 L2 mm	 L1 mm		 EAN 4016707...	 12345
8,0	70	120	1	240003	719 080 120

FOR USE IN

- Universal hole saw M16 GOLDCRAFT [66]

PACKAGING



711 HOLLOW CORE M16 ASSEMBLY, SDS-PLUS

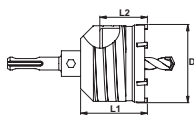

DRIVE

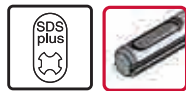

D Ø mm	D Ø "	L2 mm	L1 mm		EAN 4016707	12345
50,0	1 3/32	60	80	1	160165	711 713 050
65,0	2 9/16	52	72	1	160172	711 713 065
68,0	2 11/16	52	72	1	160219	711 713 068
80,0	3 5/32	60	80	1	160189	711 713 080

EXECUTION

- SDS-plus holder, short
- With Centre drill bit
- With internal M 16 thread
- 6 carbide cutters
- Burnished and hardened
- Made of high tempered steel with extra thick wall from 65 mm Ø without cross-bore

FOR USE IN

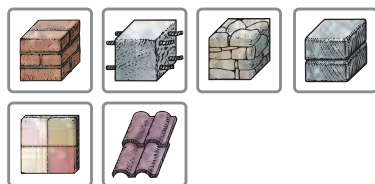

APPLICATION

- Locating shank M16 hexagon [70]
- Locating shank M16 for SDS-plus [71]
- Centre drill bit for locating shank M16 M16 [71]
- Locating shank M16 SDS-plus TURBOKEIL complete [72]

PACKAGING



710 HOLLOW CORE M16

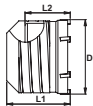

EXECUTION

- With internal M 16 thread
- 4 carbide cutters for 25 mm \emptyset
- 6 carbide cutters for 30 - 80 mm diameter
- 8 carbide cutters from 90 mm diameter
- Burnished and hardened
- Made of high tempered steel with extra thick wall from 65 mm \emptyset without cross-bore

FOR USE IN

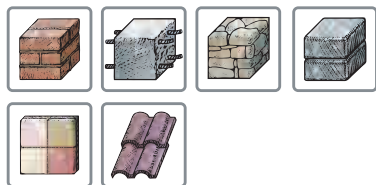

APPLICATION

- Locating shank M16 hexagon [70]
- Locating shank M16 for SDS-plus [71]
- Centre drill bit for locating shank M16 M16 [71]
- Locating shank M16 SDS-plus TURBOKEIL complete [72]

PACKAGING

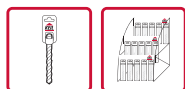

[164]

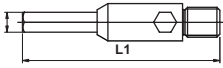

D \emptyset mm	D \emptyset "	L2 mm	L1 mm		 EAN 4016707...	 712345
25,0	1	60	80	1	160011	710 000 025
30,0	1 3/16	60	80	1	160028	710 000 030
35,0	1 1/8	60	80	1	160042	710 000 035
40,0	1 1/16	60	80	1	160059	710 000 040
45,0	1 1/4	60	80	1	160066	710 000 045
50,0	1 3/32	60	80	1	160073	710 000 050
55,0	2 3/16	52	72	1	160271	711 000 055
60,0	2 3/8	52	72	1	160158	711 000 060
65,0	2 9/16	52	72	1	160103	711 000 065
68,0	2 11/16	52	72	1	160134	711 000 068
80,0	3 5/32	60	80	1	160110	711 000 080
90,0	3 17/32	60	80	1	160127	711 000 090
100,0	3 15/16	60	80	1	160196	711 000 100

712 LOCATING SHANK M16 HEXAGON



DRIVE



L1 mm	SW mm		 EAN 4016707	 12345
100	11,00	1	160202	712 080 120
200	11,00	1	160226	712 200 120
350	11,00	1	160240	712 350 120

EXECUTION

- With external M16 thread
- With hexagonal drive

APPLICATION

- In all rotary and percussion drilling machines
- Hollow core M16 [69]
- Centre drill bit for locating shank M16 [71]
- Universal hole saw M16 GOLDCRAFT [66]
- Centre drill bit GOLDCRAFT for locating shank M16 [67]

PACKAGING



713 LOCATING SHANK M16 SDS-PLUS

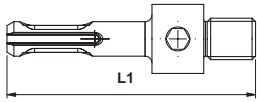

DRIVE



L1 mm		EAN 4016707...	 12345
105	1	160301	713 080 120
200	1	160332	713 200 120
350	1	160325	713 300 120

EXECUTION

- With external M16 thread
- With SDS-plus drive on machine side

APPLICATION

- In all hammer drilling machines with SDSplus and HILTI TE-C locking
- Hollow core M16 [69]
- Centre drill bit for locating shank M16 [71]
- Universal hole saw M16 GOLDCRAFT [66]
- Centre drill bit GOLDCRAFT for locating shank M16 [67]

PACKAGING

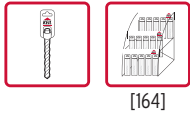

715 CENTRE DRILL BIT FOR LOCATING SHANK M16

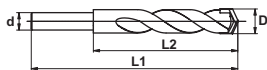

DRIVE



D Ø mm	D Ø "	L2 mm	L1 mm		EAN 4016707...	 12345
8,0	5/16	72	120	1	916168	715 080 120

APPLICATION

- Hollow core M16 [69]

PACKAGING



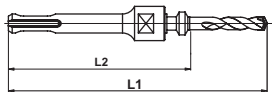

714 LOCATING SHANK M16 SDS-PLUS TURBOKEIL COMPLETE



DRIVE



L1 mm	L mm		EAN 4016707...	
178	110	1	160424	714 110 178
268	200	1	160431	714 200 268
418	350	1	160448	714 350 418

EXECUTION



- Solid construction in one piece with centre drill bit
- With external M16 thread
- With SDS-plus drive on machine side

APPLICATION

- In all hammer drilling machines with SDS-plus and HILTI TE-C locking
- Hollow core M16 [68+69]

PACKAGING



800 QUICK BIT HOLDER FOR BITS AND KEILBIT



DRIVE



	EAN 4016707...	
1	270321	800 000 008

EXECUTION

- Non-magnetic bit holder with "+" bit locking
- DIN 3126 - E 6.3 and C 6.3

APPLICATION

- Only for rotary use

PACKAGING



METAL DRILL BITS



307 HSS-E DIN 338 cobalt	76-79
311 HSS TIN DIN 338 steel drill bit	80-81
302 HSS DIN 338, ground, split point	82-85
300 HSS DIN 338, standard	86-90
300 HSS DIN 338, standard, shank reduced	91
340 HSS DIN 340, ground, split point, long	92
342 HSS DIN 1869, ground, extra long	93
344 HSS hollow section drill bit / Facade drill bit	94
345 HSS DIN 345 morse taper	95-96
303 HSS DIN 1897 pilot drill bit, ground, split point, extra short	97
310 HSS DIN 8037 carbide tipped	98
312 HSS-G Speeder DIN 338 RN metal drill bit	99
304 HSS Double end drill bit, ground, split point	100
315 HSS Drill bit KEILBIT, ground	101
317 HSS combination tool KEILBIT	102
329 HSS countersink KEILBIT	103
327 HSS countersink 90° DIN 335 C	104
328 HSS deburring countersink	105
326 HSS tube and sheet drill bit	106
325 HSS step drill	107
140 Scriber	108
320 HSS hole saw bi-metal	109-112

METAL DRILL BITS

Nothing stops the metal drill bits because we offer a drill bit for every application.

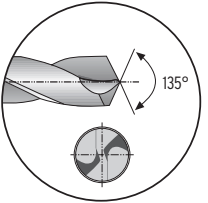

HSS-E TWIST DRILL BIT

The HSS-E drill bit is a cobalt alloyed high performance drill bit. Even with insufficient cooling it has reserve in heat resistance. Due to the alloying addition of 5 % Co in the cutting material these drill bits can be used for working with work pieces with a tensile strength of over 800N/m².

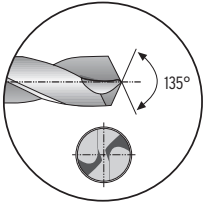

HSS TIN DRILL BIT SPLIT POINT

This high-quality drill bit is coated with titan-nitride. It is especially suitable for drilling in alloyed and unalloyed steel, sheet metal, non-ferrous metal, steel, cast metal and plastics. The HSS-TIN can be used in steel and cast steel up to 900N/mm² strength. It is a precision tool according to DIN 338 RN for best accuracy grade.

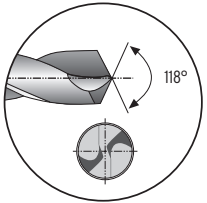

HSS TWIST DRILL BIT SPLIT POINT

This drill bit allows precise pilot drilling even on diagonal surfaces. The advance force decreases by 50 %. It has the best possible true running accuracy and therefore produces exact round holes. It has a long tool life and due to its conically strengthened high resistance against fracture.

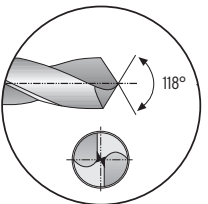

HSS TWIST DRILL BIT

Due to its robust thickness of core and a distinctive hardness this drill bit has a long tool life. Especially when drilling with diameters below 6 mm the anti-torsion capability is very high while the danger of fracture is low. It is very suitable for working with alloyed and unalloyed steel, non ferrous metals, cast iron and hard plastics.

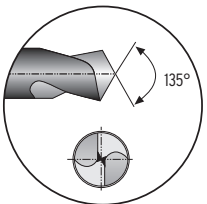

HSS PILOT DRILL BIT

The HSS pilot drill is profile ground, right hand cutting, extra short and cylindrical. The HSS pilot drill bit allows exact pilot drilling without slipping due to its self centering tip. This extra short drill bit is particularly suitable for use with hand-held machines.

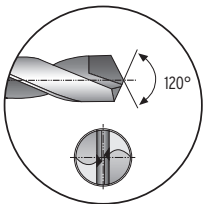

HSS TWIST DRILL BIT WITH CARBIDE BIT

The drill bit has been ground with diamond wheels to the highest accuracy. The 2-bevel sharpening builds a centering tip which is located exactly in the drilling axis whereby the drill bit centers itself. When working with CNC-machines it offers best performance.

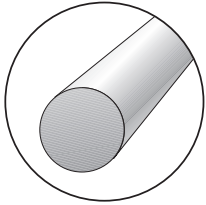

CYLINDRICAL SHAFT

Tools with round shaft are the top selling drilling tools. The round shaft is fitting into all three-jaw chucks and quick change chuck.

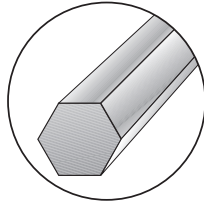

HEXAGONAL SHAFT (10.0 MM)

The hexagonal shank offers a better transmission of rotation especially when working with big diameters and long drill bits.

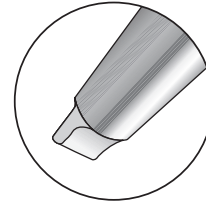

MORSE TAPER

The Morse taper (MK) is the standardised shape of a tool conus for clamping tools, e.g. drill bits with big diameters, reamers and chuck in the tool intake of a machine tool. Most tool intakes of drilling machines and turning lathes have the sizes MK2 up to MK6.

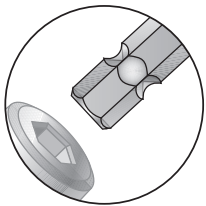

KEILBIT (E 6.3 MM)

Modern cordless screwdrivers are extremely powerful and can definitely be used for drilling. The KEILBIT has specially been invented for the fast and direct application in these machines. No change of machines is necessary anymore. For the various materials we offer different alternatives of the KEILBIT.

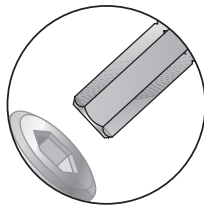

KEILBIT (C 6.3 MM)

This is a different kind of shaft of the KEILBIT with short hexagonal shank and short drill bit.

307 HSS-E DIN 338 COBALT, GROUND, SPLIT POINT

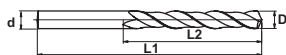

DRIVE



EXECUTION

- Profile-ground
- Right-hand cutting, type N
- 5 % cobalt
- Short, cylindrical
- 135° conical section
- Cross-ground finish to DIN 1412 C (from \varnothing 3,0 mm)
- Diametral tolerance h8

FOR USE IN



- Materials with a high strength above 800 N/mm² which are difficult to cut
- Special alloys
- Solder resistant steel
- Stainless steel V2A -V4A

APPLICATION

- In all rotary and percussion drilling machines
- In machines for mechanical processing
- Only for rotary use

PACKAGING



against
surcharge

[146+147]

[147]

D Ø mm	L2 mm	L1 mm	d Ø mm		 EAN 4016707...	 12345
1,00	12	34	1,0	10	060014	307 000 100
1,10	14	36	1,1	10	064869	307 000 110
1,20	16	38	1,2	10	064876	307 000 120
1,30	16	38	1,3	10	064883	307 000 130
1,40	18	40	1,4	10	064890	307 000 140
1,50	18	40	1,5	10	060069	307 000 150
1,60	20	43	1,6	10	064906	307 000 160
1,70	20	43	1,7	10	064913	307 000 170
1,80	22	46	1,8	10	064920	307 000 180
1,90	22	46	1,9	10	064937	307 000 190
2,00	24	49	2,0	10	060113	307 000 200
2,10	24	49	2,1	10	064944	307 000 210
2,20	27	53	2,2	10	064951	307 000 220
2,30	27	53	2,3	10	064968	307 000 230
2,40	30	57	2,4	10	064975	307 000 240
2,50	30	57	2,5	10	060168	307 000 250
2,60	30	57	2,6	10	064982	307 000 260
2,70	33	61	2,7	10	064999	307 000 270
2,80	33	61	2,8	10	065002	307 000 280
2,90	33	61	2,9	10	065019	307 000 290
3,00	33	61	3,0	10	060212	307 000 300
3,10	36	65	3,1	10	065026	307 000 310
3,20	36	65	3,2	10	060236	307 000 320
3,30	36	65	3,3	10	060243	307 000 330
3,40	39	70	3,4	10	065033	307 000 340
3,50	39	70	3,5	10	060267	307 000 350
3,60	39	70	3,6	10	065040	307 000 360
3,70	39	70	3,7	10	065057	307 000 370
3,80	43	75	3,8	10	065064	307 000 380
3,90	43	75	3,9	10	065071	307 000 390
4,00	43	75	4,0	10	060311	307 000 400
4,10	43	75	4,1	10	060328	307 000 410
4,20	43	75	4,2	10	060335	307 000 420
4,30	47	80	4,3	10	065088	307 000 430
4,40	47	80	4,4	10	065095	307 000 440
4,50	47	80	4,5	10	060366	307 000 450
4,60	47	80	4,6	10	065101	307 000 460
4,70	47	80	4,7	10	065118	307 000 470
4,80	52	86	4,8	10	060397	307 000 480
4,90	52	86	4,9	10	065125	307 000 490
5,00	52	86	5,0	10	060410	307 000 500
5,10	52	86	5,1	10	060427	307 000 510
5,20	52	86	5,2	10	060434	307 000 520
5,30	52	86	5,3	10	065132	307 000 530
5,40	57	93	5,4	10	065149	307 000 540
5,50	57	93	5,5	10	060465	307 000 550

307 HSS-E DIN 338 COBALT, GROUND, SPLIT POINT

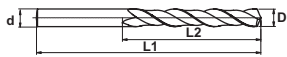

DRIVE



EXECUTION

- Profile-ground
- Right-hand cutting, type N
- 5 % cobalt
- Short, cylindrical
- 135° conical section
- Cross-ground finish to DIN 1412 C (from \varnothing 3,0 mm)
- Diametral tolerance h8

FOR USE IN



- Materials with a high strength above 800 N/mm² which are difficult to cut
- Special alloys
- Solder resistant steel
- Stainless steel V2A -V4A

APPLICATION

- In all rotary and percussion drilling machines
- In machines for mechanical processing
- Only for rotary use

PACKAGING



against
surcharge

[146+147]

[147]

D Ø mm	L2 mm	L1 mm	d Ø mm	Icon	FAN 4016707	Icon
5,60	57	93	5,6	10	065156	307 000 560
5,70	57	93	5,7	10	065163	307 000 570
5,80	57	93	5,8	10	065170	307 000 580
5,90	57	93	5,9	10	065187	307 000 590
6,00	57	93	6,0	10	060519	307 000 600
6,10	63	101	6,1	10	065194	307 000 610
6,20	63	101	6,2	10	065200	307 000 620
6,30	63	101	6,3	10	065217	307 000 630
6,40	63	101	6,4	10	065224	307 000 640
6,50	63	101	6,5	10	060564	307 000 650
6,60	63	101	6,6	10	065231	307 000 660
6,70	63	101	6,7	10	065248	307 000 670
6,80	69	109	6,8	10	060595	307 000 680
6,90	69	109	6,9	10	065255	307 000 690
7,00	69	109	7,0	10	060618	307 000 700
7,10	69	109	7,1	10	065262	307 000 710
7,20	69	109	7,2	10	065279	307 000 720
7,30	69	109	7,3	10	065286	307 000 730
7,40	69	109	7,4	10	065293	307 000 740
7,50	69	109	7,5	10	060663	307 000 750
7,60	75	117	7,6	10	065309	307 000 760
7,70	75	117	7,7	10	065316	307 000 770
7,80	75	117	7,8	10	065323	307 000 780
7,90	75	117	7,9	10	065330	307 000 790
8,00	75	117	8,0	10	060717	307 000 800
8,10	75	117	8,1	10	065347	307 000 810
8,20	75	117	8,2	10	065354	307 000 820
8,30	75	117	8,3	10	065361	307 000 830
8,40	75	117	8,4	10	065378	307 000 840
8,50	75	117	8,5	10	060762	307 000 850
8,60	81	125	8,6	10	065385	307 000 860
8,70	81	125	8,7	10	065392	307 000 870
8,80	81	125	8,8	10	065408	307 000 880
8,90	81	125	8,9	10	065415	307 000 890
9,00	81	125	9,0	10	060816	307 000 900
9,10	81	125	9,1	10	065422	307 000 910
9,20	81	125	9,2	10	065439	307 000 920
9,30	81	125	9,3	10	065446	307 000 930
9,40	81	125	9,4	10	065453	307 000 940
9,50	81	125	9,5	10	060861	307 000 950
9,60	87	133	9,6	10	065460	307 000 960
9,70	87	133	9,7	10	065477	307 000 970
9,80	87	133	9,8	10	065484	307 000 980
9,90	87	133	9,9	10	065491	307 000 990
10,00	87	133	10,0	10	060915	307 001 000
10,20	87	133	10,2	5	060939	307 001 020

307 HSS-E DIN 338 COBALT, GROUND, SPLIT POINT

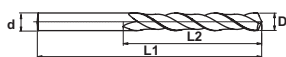

DRIVE



D ø mm	L2 mm	L1 mm	d ø mm		EAN 4016707...	
10,50	87	133	10,5	5	060960	307 001 050
11,00	94	142	11,0	5	061011	307 001 100
11,50	94	142	11,5	5	061066	307 001 150
12,00	101	151	12,0	5	061110	307 001 200
12,50	101	151	12,5	5	061165	307 001 250
13,00	101	151	13,0	5	061219	307 001 300

EXECUTION

- Profile-ground
- Right-hand cutting, type N
- 5 % cobalt
- Short, cylindrical
- 135° conical section
- Cross-ground finish to DIN 1412 C (from Ø 3,0 mm)
- Diametral tolerance h8

FOR USE IN



- Materials with a high strength above 800 N/mm² which are difficult to cut
- Special alloys
- Solder resistant steel
- Stainless steel V2A -V4A

APPLICATION

- In all rotary and percussion drilling machines
- In machines for mechanical processing
- Only for rotary use

PACKAGING



against
surcharge

[146+147]

[147]

HSS-E DIN 338 COBALT, GROUND, SPLIT POINT

- Centre punching is not necessary
- Direct drilling without prior centering or drilling of a pilot hole
- Safe pilot hole drilling, even in slanting surfaces, in pipes and welds
- The feeding power is reduced by up to 50 %
- The drill bit facilitates an increase in drilling progress by up to 45 %.
- Even chip removal and reduction of chip friction
- Extremely true running and precise round holes
- No jamming of the main cutting edge and no slipping of the drill bit with through boring holes
- High fracture strength and long tool life
- Reduced friction due to reduced diameter in the shank direction
- Higher breaking strength through conically reinforced drilling core
- Long operating time and fast drilling progress through chemical thermal method of hardening and accurate cross-ground finish
- Due to the alloying addition of 5% Co these drill bits are well-suited for work pieces with a tensile strength of more than 800 N/mm²
- Extra high temperature strength to cope with suboptimal supply of coolant
- Up to 20 % higher durability than identically constructed HSS drill bits used under the same operating conditions

307 HSS-E DIN 338 COBALT, GROUND, SPLIT POINT IN SELF-SERVICE POUCH

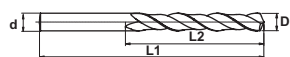

DRIVE



EXECUTION

- In self-service pouch
- Profile-ground
- Right-hand cutting, type N
- 5 % cobalt
- Short, cylindrical
- 135° conical section
- Cross-ground finish to DIN 1412 C (from \varnothing 3,0 mm)
- Diametral tolerance h8

FOR USE IN



- Materials with a high strength above 800 N/mm² which are difficult to cut
- Special alloys
- Solder resistant steel
- Stainless steel V2A -V4A

APPLICATION

- In all rotary and percussion drilling machines
- In machines for mechanical processing
- Only for rotary use

PACKAGING

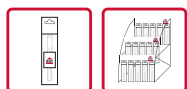

[165]

Comments

- Other dimensions p. 76-78

D Ø mm	L2 mm	L1 mm			FAN 4016707...	
1,00	12	34	2	5	062926	307 320 100
1,50	18	40	2	5	062933	307 320 150
2,00	24	49	2	5	062940	307 320 200
2,50	30	57	2	5	062957	307 320 250
3,00	33	61	2	5	062964	307 320 300
3,20	36	65	2	5	062971	307 320 320
3,30	36	65	2	5	062988	307 320 330
3,50	39	70	2	5	062995	307 320 350
4,00	43	75	1	10	063084	307 300 400
4,20	43	75	1	10	063091	307 300 420
4,50	47	80	1	10	063107	307 300 450
4,80	52	86	1	10	063336	307 300 480
5,00	52	86	1	10	063114	307 300 500
5,50	57	93	1	10	063138	307 300 550
6,00	57	93	1	10	063145	307 300 600
6,50	63	101	1	10	063152	307 300 650
7,00	69	109	1	10	063176	307 300 700
7,50	69	109	1	10	063183	307 300 750
8,00	75	117	1	10	063190	307 300 800
8,50	75	117	1	10	063206	307 300 850
9,00	81	125	1	10	063213	307 300 900
9,50	81	125	1	10	063220	307 300 950
10,00	87	133	1	10	063237	307 301 000
10,20	87	133	1	5	063244	307 301 020
10,50	87	133	1	5	063251	307 301 050
11,00	94	142	1	5	063268	307 301 100
11,50	94	142	1	5	063275	307 301 150
12,00	101	151	1	5	063282	307 301 200
12,50	101	151	1	5	063299	307 301 250
13,00	101	151	1	5	063305	307 301 300

311 HSS TIN DIN 338 STEEL DRILL BITS

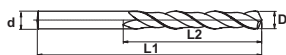

DRIVE



EXECUTION

- Right hand cutting
- TIN coated
- Cross-ground finish and 135° conical section for optimum centering when pilot drilling

FOR USE IN





APPLICATION

- For drilling alloyed and unalloyed steel, iron, cast iron, sheet metal, non-ferrous metals and plastics
- Ideal for heavy-duty use thanks to long service life and powerful drilling performance

PACKAGING



[148]

D Ø mm	L2 mm	L1 mm			EAN 4016707...	
1,00	12	34	1	10	919602	311 000 010
1,50	18	40	1,5	10	919619	311 000 015
2,00	24	49	2	10	919626	311 000 020
2,50	30	57	2,5	10	919633	311 000 025
3,00	33	61	3	10	919640	311 000 030
3,20	36	65	3,2	10	919657	311 000 032
3,30	36	65	3,3	10	919664	311 000 033
3,50	39	70	3,5	10	919671	311 000 035
4,00	43	75	4	10	919688	311 000 040
4,20	43	75	4,2	10	919695	311 000 042
4,50	47	80	4,5	10	919701	311 000 045
4,80	52	86	4,8	10	919718	311 000 048
5,00	52	86	5	10	919725	311 000 050
5,50	57	93	5,5	10	919732	311 000 055
6,00	57	93	6	10	919749	311 000 060
6,50	63	101	6,5	10	919756	311 000 065
7,00	69	101	7	10	919763	311 000 070
7,50	69	109	7,5	10	919770	311 000 075
8,00	75	117	8	10	919787	311 000 080
8,50	75	117	8,5	10	919794	311 000 085
9,00	81	125	9	10	919800	311 000 090
9,50	81	125	9,5	10	919817	311 000 095
10,00	87	133	10	10	919824	311 000 100
10,50	87	133	10,5	10	919831	311 000 105
11,00	94	142	11	5	919848	311 000 110
11,50	94	142	11,5	5	919855	311 000 115
12,00	101	151	12	5	919862	311 000 120
12,50	101	151	12,5	5	919879	311 000 125
13,00	101	151	13	5	919886	311 000 130

311 HSS TIN DIN 338 STEEL DRILL BITS IN SELF-SERVICE POUCH

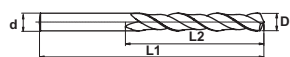

DRIVE



EXECUTION

- Right hand cutting
- TIN coated
- Cross-ground finish and 135° conical section for optimum centering when pilot drilling

FOR USE IN



APPLICATION

- For drilling alloyed and unalloyed steel, iron, cast iron, sheet metal, non-ferrous metals and plastics
- Ideal for heavy-duty use thanks to long service life and powerful drilling performance

PACKAGING

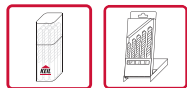

[148]

D Ø mm	L2 mm	L1 mm			EAN 4016707...	
1,00	12	34	1	2	920363	311 320 010
1,50	18	40	1,5	2	920370	311 320 015
2,00	24	49	2	2	920387	311 320 020
2,50	30	57	2,5	2	920394	311 320 025
3,00	33	61	3	2	920400	311 320 030
3,20	36	65	3,2	2	920417	311 320 032
3,30	36	65	3,3	2	920424	311 320 033
3,50	39	70	3,5	2	920431	311 320 035
4,00	43	75	4	1	920448	311 300 040
4,20	43	75	4,2	1	920455	311 300 042
4,50	47	80	4,5	1	920462	311 300 045
4,80	52	86	4,8	1	920479	311 300 048
5,00	52	86	5	1	920486	311 300 050
5,50	57	93	5,5	1	920493	311 300 055
6,00	57	93	6	1	920509	311 300 060
6,50	63	101	6,5	1	920516	311 300 065
7,00	69	101	7	1	920523	311 300 070
7,50	69	109	7,5	1	920530	311 300 075
8,00	75	117	8	1	920547	311 300 080
8,50	75	117	8,5	1	920554	311 300 085
9,00	81	125	9	1	920561	311 300 090
9,50	81	125	9,5	1	920578	311 300 095
10,00	87	133	10	1	920585	311 300 100
10,50	87	133	10,5	1	920592	311 300 105
11,00	94	142	11	1	920608	311 300 110
11,50	94	142	11,5	1	920615	311 300 115
12,00	101	151	12	1	920622	311 300 120
12,50	101	151	12,5	1	920639	311 300 125
13,00	101	151	13	1	920646	311 300 130

302 HSS DIN 338 GROUND, SPLIT POINT



DRIVE



EXECUTION

- Profile-ground
- Right-hand cutting, type N
- High-performance high-speed steel
- Ground from the solid
- Short, cylindrical
- 118° conical section
- Cross-ground finish to DIN 1412 C (from \varnothing 3,0 mm)
- Diametral tolerance h8

FOR USE IN



APPLICATION

- In all rotary and percussion drilling machines
- In machines for mechanical processing
- Only for rotary use

PACKAGING

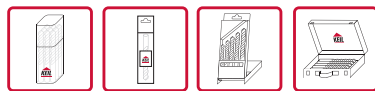

against
surcharge

[149+150]

[150]

D \varnothing mm	L2 mm	L1 mm	d \varnothing mm		EAN 4016707...	
1,00	12	34	1,0	10	120015	302 000 100
1,10	14	36	1,1	10	120794	302 000 110
1,20	16	38	1,2	10	120800	302 000 120
1,30	16	38	1,3	10	120817	302 000 130
1,40	18	40	1,4	10	120824	302 000 140
1,50	18	40	1,5	10	120022	302 000 150
1,60	20	43	1,6	10	120831	302 000 160
1,70	20	43	1,7	10	120848	302 000 170
1,80	22	46	1,8	10	120855	302 000 180
1,90	22	46	1,9	10	120862	302 000 190
2,00	24	49	2,0	10	120039	302 000 200
2,10	24	49	2,1	10	120879	302 000 210
2,20	27	53	2,2	10	120886	302 000 220
2,30	27	53	2,3	10	120893	302 000 230
2,40	30	57	2,4	10	120909	302 000 240
2,50	30	57	2,5	10	120046	302 000 250
2,60	30	57	2,6	10	120916	302 000 260
2,70	33	61	2,7	10	120923	302 000 270
2,80	33	61	2,8	10	120930	302 000 280
2,90	33	61	2,9	10	120947	302 000 290
3,00	33	61	3,0	10	120053	302 000 300
3,10	36	65	3,1	10	120954	302 000 310
3,20	36	65	3,2	10	120060	302 000 320
3,30	36	65	3,3	10	120077	302 000 330
3,40	39	70	3,4	10	120978	302 000 340
3,50	39	70	3,5	10	120084	302 000 350
3,60	39	70	3,6	10	120985	302 000 360
3,70	39	70	3,7	10	120992	302 000 370
3,80	43	75	3,8	10	121005	302 000 380
3,90	43	75	3,9	10	121012	302 000 390
4,00	43	75	4,0	10	120091	302 000 400
4,10	43	75	4,1	10	120107	302 000 410
4,20	43	75	4,2	10	120114	302 000 420
4,30	47	80	4,3	10	121029	302 000 430
4,40	47	80	4,4	10	121036	302 000 440
4,50	47	80	4,5	10	120121	302 000 450
4,60	47	80	4,6	10	121043	302 000 460
4,70	47	80	4,7	10	121050	302 000 470
4,80	52	86	4,8	10	120138	302 000 480
4,90	52	86	4,9	10	121067	302 000 490
5,00	52	86	5,0	10	120145	302 000 500
5,10	52	86	5,1	10	120152	302 000 510
5,20	52	86	5,2	10	120169	302 000 520
5,30	52	86	5,3	10	121074	302 000 530
5,40	57	93	5,4	10	121081	302 000 540
5,50	57	93	5,5	10	120176	302 000 550

302 HSS DIN 338 GROUND, SPLIT POINT



DRIVE



EXECUTION

- Profile-ground
- Right-hand cutting, type N
- High-performance high-speed steel
- Ground from the solid
- Short, cylindrical
- 118° conical section
- Cross-ground finish to DIN 1412 C (from \varnothing 3,0 mm)
- Diametral tolerance h8

FOR USE IN



APPLICATION

- In all rotary and percussion drilling machines
- In machines for mechanical processing
- Only for rotary use

PACKAGING

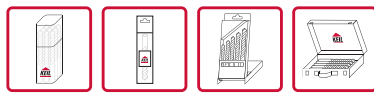

against
surcharge

[149+150]

[150]

D ø mm	L2 mm	L1 mm	d ø mm	PAK	FAN 4016707...	12345
5,60	57	93	5,6	10	121098	302 000 560
5,70	57	93	5,7	10	121104	302 000 570
5,80	57	93	5,8	10	121111	302 000 580
5,90	57	93	5,9	10	121128	302 000 590
6,00	57	93	6,0	10	120183	302 000 600
6,10	63	101	6,1	10	121135	302 000 610
6,20	63	101	6,2	10	121142	302 000 620
6,30	63	101	6,3	10	121159	302 000 630
6,40	63	101	6,4	10	121166	302 000 640
6,50	63	101	6,5	10	120190	302 000 650
6,60	63	101	6,6	10	121173	302 000 660
6,70	63	101	6,7	10	121180	302 000 670
6,80	69	109	6,8	10	120206	302 000 680
6,90	69	109	6,9	10	121197	302 000 690
7,00	69	109	7,0	10	120213	302 000 700
7,10	69	109	7,1	10	121203	302 000 710
7,20	69	109	7,2	10	121210	302 000 720
7,30	69	109	7,3	10	121227	302 000 730
7,40	69	109	7,4	10	121234	302 000 740
7,50	69	109	7,5	10	120220	302 000 750
7,60	75	117	7,6	10	121241	302 000 760
7,70	75	117	7,7	10	121258	302 000 770
7,80	75	117	7,8	10	121265	302 000 780
7,90	75	117	7,9	10	121272	302 000 790
8,00	75	117	8,0	10	120237	302 000 800
8,10	75	117	8,1	10	121289	302 000 810
8,20	75	117	8,2	10	121296	302 000 820
8,30	75	117	8,3	10	121302	302 000 830
8,40	75	117	8,4	10	121319	302 000 840
8,50	75	117	8,5	10	120244	302 000 850
8,60	81	125	8,6	10	121326	302 000 860
8,70	81	125	8,7	10	121333	302 000 870
8,80	81	125	8,8	10	121340	302 000 880
8,90	81	125	8,9	10	121357	302 000 890
9,00	81	125	9,0	10	120251	302 000 900
9,10	81	125	9,1	10	121364	302 000 910
9,20	81	125	9,2	10	121371	302 000 920
9,30	81	125	9,3	10	121388	302 000 930
9,40	81	125	9,4	10	121395	302 000 940
9,50	81	125	9,5	10	120268	302 000 950
9,60	87	133	9,6	10	121401	302 000 960
9,70	87	133	9,7	10	121418	302 000 970
9,80	87	133	9,8	10	121425	302 000 980
9,90	87	133	9,9	10	121432	302 000 990
10,00	87	133	10,0	10	120275	302 001 000
10,20	87	133	10,2	5	120282	302 001 020

302 HSS DIN 338 GROUND, SPLIT POINT

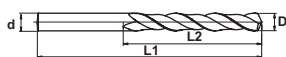

DRIVE



D ø mm	L2 mm	L1 mm	d ø mm		EAN 4016707...	12345
10,50	87	133	10,5	5	120299	302 001 050
11,00	94	142	11,0	5	120305	302 001 100
11,50	94	142	11,5	5	120312	302 001 150
12,00	101	151	12,0	5	120329	302 001 200
12,50	101	151	12,5	5	120336	302 001 250
13,00	101	151	13,0	5	120343	302 001 300
13,50	108	160	13,5	5	121449	302 001 350
14,00	108	160	14,0	5	121456	302 001 400
14,50	114	169	14,5	5	121463	302 001 450
15,00	114	169	15,0	5	121470	302 001 500
15,50	120	178	15,5	5	121487	302 001 550
16,00	120	178	16,0	5	121494	302 001 600

EXECUTION

- Profile-ground
- Right-hand cutting, type N
- High-performance high-speed steel
- Ground from the solid
- Short, cylindrical
- 118° conical section
- Cross-ground finish to DIN 1412 C (from Ø 3,0 mm)
- Diametral tolerance h8

FOR USE IN



APPLICATION

- In all rotary and percussion drilling machines
- In machines for mechanical processing
- Only for rotary use

PACKAGING



against
surcharge

[149+150]

[150]

302 HSS DIN 338 GROUND, SPLIT POINT, IN SELF-SERVICE POUCH

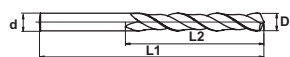

DRIVE



EXECUTION

- Profile-ground
- Right-hand cutting, type N
- High-performance high-speed steel
- Ground from the solid
- Short, cylindrical
- 118° conical section
- Cross-ground finish to DIN 1412 C (from Ø 3,0 mm)
- Diametral tolerance h8

FOR USE IN



APPLICATION

- In all rotary and percussion drilling machines
- In machines for mechanical processing
- Only for rotary use

PACKAGING



[165]

Comments

- Other dimensions S.82-84

D Ø mm	L2 mm	L1 mm			FAN 4016707...	
1,00	12	34	2	5	122637	302 320 100
1,50	18	40	2	5	122644	302 320 150
2,00	24	49	2	5	122651	302 320 200
2,50	30	57	2	5	120718	302 320 250
3,00	33	61	2	5	120725	302 320 300
3,20	36	65	2	5	120732	302 320 320
3,30	36	65	2	5	122668	302 320 330
3,50	39	70	2	5	120749	302 320 350
4,00	43	75	1	10	120459	302 300 400
4,20	43	75	1	10	120473	302 300 420
4,50	47	80	1	10	120480	302 300 450
4,80	52	86	1	10	120497	302 300 480
5,00	52	86	1	10	120503	302 300 500
5,50	57	93	1	10	120534	302 300 550
6,00	57	93	1	10	120541	302 300 600
6,50	63	101	1	10	120558	302 300 650
7,00	69	109	1	10	120572	302 300 700
7,50	69	109	1	10	120589	302 300 750
8,00	75	117	1	10	120596	302 300 800
8,50	75	117	1	10	120602	302 300 850
9,00	81	125	1	10	120619	302 300 900
9,50	81	125	1	10	120626	302 300 950
10,00	87	133	1	10	120633	302 301 000
10,20	87	133	1	5	120640	302 301 020
10,50	87	133	1	5	120657	302 301 050
11,00	94	142	1	5	120664	302 301 100
11,50	94	142	1	5	120671	302 301 150
12,00	101	151	1	5	120688	302 301 200
12,50	101	151	1	5	120695	302 301 250
13,00	101	151	1	5	120701	302 301 300

300 HSS DIN 338 STANDARD

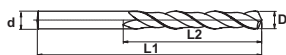

DRIVE



EXECUTION

- Right-hand cutting, type N
- High-performance high-speed steel
- Short, cylindrical
- 118° conical section
- Diametral tolerance h8

FOR USE IN



APPLICATION

- In all rotary and percussion drilling machines
- In machines for mechanical processing
- Only for rotary use

PACKAGING

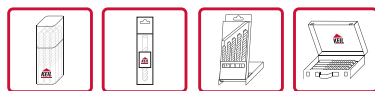

against
surcharge

[151-152]

[152]

D ø mm	L2 mm	L1 mm	d ø mm		EAN 4016707...	
0,50	6	22	0,5	10	040016	300 000 050
0,60	7	24	0,6	10	040023	300 000 060
0,70	9	28	0,7	10	040030	300 000 070
0,80	10	30	0,8	10	040047	300 000 080
0,90	11	32	0,9	10	040054	300 000 090
1,00	12	34	1,0	10	040061	300 000 100
1,10	14	36	1,1	10	040078	300 000 110
1,20	16	38	1,2	10	040085	300 000 120
1,25	16	38	1,3	10	040092	300 000 125
1,30	16	38	1,3	10	040108	300 000 130
1,40	18	40	1,4	10	040115	300 000 140
1,50	18	40	1,5	10	040122	300 000 150
1,60	20	43	1,6	10	040139	300 000 160
1,70	20	43	1,7	10	040146	300 000 170
1,75	22	46	1,8	10	040153	300 000 175
1,80	22	46	1,8	10	040160	300 000 180
1,90	22	46	1,9	10	040177	300 000 190
2,00	24	49	2,0	10	040184	300 000 200
2,10	24	49	2,1	10	040191	300 000 210
2,20	27	53	2,2	10	040207	300 000 220
2,25	27	53	2,3	10	040214	300 000 225
2,30	27	53	2,3	10	040221	300 000 230
2,40	30	57	2,4	10	040238	300 000 240
2,50	30	57	2,5	10	040245	300 000 250
2,60	30	57	2,6	10	040252	300 000 260
2,70	33	61	2,7	10	040269	300 000 270
2,75	33	61	2,8	10	040276	300 000 275
2,80	33	61	2,8	10	040283	300 000 280
2,90	33	61	2,9	10	040290	300 000 290
3,00	33	61	3,0	10	040306	300 000 300
3,10	36	65	3,1	10	040313	300 000 310
3,20	36	65	3,2	10	040320	300 000 320
3,25	36	65	3,3	10	040337	300 000 325
3,30	36	65	3,3	10	040344	300 000 330
3,40	39	70	3,4	10	040351	300 000 340
3,50	39	70	3,5	10	040368	300 000 350
3,60	39	70	3,6	10	040375	300 000 360
3,70	39	70	3,7	10	040382	300 000 370
3,75	39	70	3,8	10	040399	300 000 375
3,80	43	75	3,8	10	040405	300 000 380
3,90	43	75	3,9	10	040412	300 000 390
4,00	43	75	4,0	10	040429	300 000 400
4,10	43	75	4,1	10	040436	300 000 410
4,20	43	75	4,2	10	040443	300 000 420
4,25	43	75	4,3	10	040450	300 000 425
4,30	47	80	4,3	10	040467	300 000 430

300 HSS DIN 338 STANDARD



DRIVE



EXECUTION

- Right-hand cutting, type N
- High-performance high-speed steel
- Short, cylindrical
- 118° conical section
- Diametral tolerance h8

FOR USE IN



APPLICATION

- In all rotary and percussion drilling machines
- In machines for mechanical processing
- Only for rotary use

PACKAGING



against
surcharge

[151-152]

[152]

D ø mm	L2 mm	L1 mm	d ø mm	10	FAN 4016707...	12345
4,40	47	80	4,4	10	040474	300 000 440
4,50	47	80	4,5	10	040481	300 000 450
4,60	47	80	4,6	10	040498	300 000 460
4,70	47	80	4,7	10	040504	300 000 470
4,75	47	80	4,8	10	040511	300 000 475
4,80	52	86	4,8	10	040528	300 000 480
4,90	52	86	4,9	10	040535	300 000 490
5,00	52	86	5,0	10	040542	300 000 500
5,10	52	86	5,1	10	040559	300 000 510
5,20	52	86	5,2	10	040566	300 000 520
5,25	52	86	5,3	10	040573	300 000 525
5,30	52	86	5,3	10	040580	300 000 530
5,40	57	93	5,4	10	040597	300 000 540
5,50	57	93	5,5	10	040603	300 000 550
5,60	57	93	5,6	10	040610	300 000 560
5,70	57	93	5,7	10	040627	300 000 570
5,75	57	93	5,8	10	040634	300 000 575
5,80	57	93	5,8	10	040641	300 000 580
5,90	57	93	5,9	10	040658	300 000 590
6,00	57	93	6,0	10	040665	300 000 600
6,10	63	101	6,1	10	040672	300 000 610
6,20	63	101	6,2	10	040689	300 000 620
6,25	63	101	6,3	10	040696	300 000 625
6,30	63	101	6,3	10	040702	300 000 630
6,40	63	101	6,4	10	040719	300 000 640
6,50	63	101	6,5	10	040726	300 000 650
6,60	63	101	6,6	10	040733	300 000 660
6,70	63	101	6,7	10	040740	300 000 670
6,75	69	109	6,8	10	040757	300 000 675
6,80	69	109	6,8	10	040764	300 000 680
6,90	69	109	6,9	10	040771	300 000 690
7,00	69	109	7,0	10	040788	300 000 700
7,10	69	109	7,1	10	040795	300 000 710
7,20	69	109	7,2	10	040801	300 000 720
7,25	69	109	7,3	10	040818	300 000 725
7,30	69	109	7,3	10	040825	300 000 730
7,40	69	109	7,4	10	040832	300 000 740
7,50	69	109	7,5	10	040849	300 000 750
7,60	75	117	7,6	10	040856	300 000 760
7,70	75	117	7,7	10	040863	300 000 770
7,75	75	117	7,8	10	040870	300 000 775
7,80	75	117	7,8	10	040887	300 000 780
7,90	75	117	7,9	10	040894	300 000 790
8,00	75	117	8,0	10	040900	300 000 800
8,10	75	117	8,1	10	040917	300 000 810
8,20	75	117	8,2	10	040924	300 000 820

300 HSS DIN 338 STANDARD

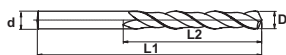

DRIVE



EXECUTION

- Right-hand cutting, type N
- High-performance high-speed steel
- Short, cylindrical
- 118° conical section
- Diametral tolerance h8

FOR USE IN



APPLICATION

- In all rotary and percussion drilling machines
- In machines for mechanical processing
- Only for rotary use

PACKAGING



against
surcharge

[151-152]

[152]

D ø mm	L2 mm	L1 mm	d ø mm		EAN 4016707...	
8,25	75	117	8,3	10	040931	300 000 825
8,30	75	117	8,3	10	040948	300 000 830
8,40	75	117	8,4	10	040955	300 000 840
8,50	75	117	8,5	10	040962	300 000 850
8,60	81	125	8,6	10	040979	300 000 860
8,70	81	125	8,7	10	040986	300 000 870
8,80	81	125	8,8	10	041006	300 000 880
8,90	81	125	8,9	10	041013	300 000 890
9,00	81	125	9,0	10	041020	300 000 900
9,10	81	125	9,1	10	041037	300 000 910
9,20	81	125	9,2	10	041044	300 000 920
9,25	81	125	9,3	10	041051	300 000 925
9,30	81	125	9,3	10	041068	300 000 930
9,50	81	125	9,5	10	041082	300 000 950
9,60	87	133	9,6	10	041099	300 000 960
9,70	87	133	9,7	10	041105	300 000 970
9,80	87	133	9,8	10	041129	300 000 980
9,90	87	133	9,9	10	041136	300 000 990
10,00	87	133	10,0	10	041143	300 001 000
10,20	87	133	10,2	5	041150	300 001 020
10,50	87	133	10,5	5	041167	300 001 050
11,00	94	142	11,0	5	041174	300 001 100
11,50	94	142	11,5	5	041181	300 001 150
12,00	101	151	12,0	5	041198	300 001 200
12,50	101	151	12,5	5	041204	300 001 250
13,00	101	151	13,0	5	041211	300 001 300
13,50	108	160	13,5	5	041228	300 001 350
14,00	108	160	14,0	5	041235	300 001 400
14,50	114	169	14,5	5	041242	300 001 450
15,00	114	169	15,0	5	041259	300 001 500
15,50	120	178	15,5	5	041266	300 001 550
16,00	120	178	16,0	5	041273	300 001 600
16,50	125	184	16,0	5	041280	300 001 650
17,00	125	184	17,0	5	041297	300 001 700
17,50	130	191	17,5	5	041303	300 001 750
18,00	130	191	18,0	5	041310	300 001 800
18,50	135	198	18,5	5	041327	300 001 850
19,00	135	198	19,0	5	041334	300 001 900
20,00	140	205	20,0	5	041358	300 002 000

300 HSS DIN 338 STANDARD



DRIVE



EXECUTION

- Right-hand cutting, type N
- High-performance high-speed steel
- Short, cylindrical
- 118° conical section
- Diametral tolerance h8

FOR USE IN



APPLICATION

- In all rotary and percussion drilling machines
- In machines for mechanical processing
- Only for rotary use

PACKAGING



against
surcharge

[151-152]

[152]



HSS DIN 338 STANDARD

- The Keil HSS twist drill bits DIN 338 standard have a high elasticity due to heat forming.
- The drill bit has a particularly robust core thickness and distinct hardness resulting in a long tool life. Cold deposition is reduced by the special surface treatment. The achieved torsional strength leads to little danger of breakage, in particular when drilling holes of less than 6 mm diameter.
- This twist drill is the conventional tool for professional use in metal.
- The drills are excellent for machining alloyed and unalloyed steel with a tensile strength up to 800 N/mm², non-iron metal, cast iron and hard plastics.

300 HSS DIN 338 STANDARD IN SELF-SERVICE POUCH



DRIVE



EXECUTION

- In SB Tasche
- Rechtsschneidend, Typ N
- Hochleistungsschnellarbeitsstahl
- Kurz, zylindrisch
- 118° Kegelmantelschliff
- Durchmesser tolerance h8

FOR USE IN



APPLICATION

- In all rotary and percussion drilling machines
- In machines for mechanical processing
- Only for rotary use

PACKAGING



[166]

D Ø mm	L2 mm	L1 mm			EAN 4016707...	
1,00	12	34	2	5	044458	300 320 100
1,50	18	40	2	5	044519	300 320 150
2,00	24	49	2	5	044571	300 320 200
2,50	30	57	2	5	044632	300 320 250
3,00	33	61	2	5	044694	300 320 300
3,20	36	65	2	5	044717	300 320 320
3,30	36	65	2	5	044731	300 320 330
3,50	39	70	2	5	044755	300 320 350
4,00	43	75	1	10	043420	300 300 400
4,20	43	75	1	10	043444	300 300 420
4,50	47	80	1	10	043482	300 300 450
4,80	52	86	1	10	043529	300 300 480
5,00	52	86	1	10	043543	300 300 500
5,50	57	93	1	10	043604	300 300 550
6,00	57	93	1	10	043666	300 300 600
6,50	63	101	1	10	043727	300 300 650
7,00	69	109	1	10	043789	300 300 700
7,50	69	109	1	10	043840	300 300 750
8,00	75	117	1	10	043901	300 300 800
8,50	75	117	1	10	043963	300 300 850
9,00	81	125	1	10	044021	300 300 900
9,50	81	125	1	10	044083	300 300 950
10,00	87	133	1	10	044144	300 301 000
10,20	87	133	1	5	044151	300 301 020
10,50	87	133	1	5	044168	300 301 050
11,00	94	142	1	5	044175	300 301 100
11,50	94	142	1	5	044182	300 301 150
12,00	101	151	1	5	044199	300 301 200
12,50	101	151	1	5	044205	300 301 250
13,00	101	151	1	5	044212	300 301 300

Comments

- Other dimensions S.85-87

300 HSS DIN 338 STANDARD, SHANK REDUCED

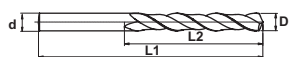

DRIVE



EXECUTION

- Right-hand cutting, type N
- High-performance high-speed steel
- Short, cylindrical
- 118° conical section
- Diametral tolerance h8

FOR USE IN



APPLICATION

- In all rotary and percussion drilling machines
- In machines for mechanical processing
- Only for rotary use

PACKAGING

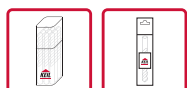

against
surcharge

D Ø mm	L2 mm	L1 mm	d Ø mm	PKT	EAN 4016707...	ARTICLE NO.
10,50	87	133	10,0	5	045516	300 105 100
11,00	94	142	10,0	5	045523	300 110 100
11,50	94	142	10,0	5	045530	300 115 100
12,00	101	151	10,0	5	045547	300 120 100
12,50	101	151	10,0	5	045554	300 125 100
13,00	101	151	10,0	5	045561	300 130 100
13,50	108	160	10,0	5	045578	300 135 100
13,50	108	160	13,0	5	045141	300 135 130
14,00	108	160	10,0	5	045585	300 140 100
14,00	108	160	13,0	5	045158	300 140 130
14,50	114	169	10,0	5	045592	300 145 100
14,50	114	169	13,0	5	045165	300 145 130
15,00	114	169	10,0	5	045608	300 150 100
15,00	114	169	13,0	5	045172	300 150 130
15,50	120	178	10,0	5	045615	300 155 100
15,50	120	178	13,0	5	045189	300 155 130
16,00	120	178	10,0	5	045622	300 160 100
16,00	120	178	13,0	5	045196	300 160 130
16,50	125	184	10,0	5	045646	300 165 100
16,50	125	184	13,0	5	045202	300 165 130
17,00	125	184	10,0	5	045639	300 170 100
17,00	125	184	13,0	5	045219	300 170 130
17,50	130	191	13,0	5	045226	300 175 130
18,00	130	191	10,0	5	045653	300 180 100
18,00	130	191	13,0	5	045233	300 180 130
18,50	135	198	13,0	5	045240	300 185 130
19,00	135	198	13,0	5	045257	300 190 130
19,50	140	205	13,0	5	045264	300 195 130
20,00	140	205	10,0	5	045660	300 200 100
20,00	140	205	13,0	5	045271	300 200 130

340 HSS DIN 340 GROUND, SPLIT POINT, LONG

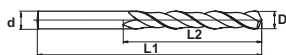

DRIVE



EXECUTION

- Profile-ground
- Right-hand cutting, type N
- High-performance high-speed steel
- Long, cylindrical
- 118° conical section
- Diametral tolerance h8

FOR USE IN



APPLICATION

- In all rotary and percussion drilling machines
- In machines for mechanical processing
- Only for rotary use

PACKAGING

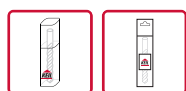

against
surcharge

Comments

- Other dimensions on request

D ø mm	L2 mm	L1 mm	d ø mm		EAN 4016707...	
2,00	56	85	2,0	10	070013	340 000 020
2,50	62	95	2,5	10	070020	340 000 025
2,90	66	100	2,9	10	070310	340 000 029
3,00	66	100	3,0	10	070037	340 000 030
3,20	69	106	3,2	10	070044	340 000 032
3,50	73	112	3,5	10	070051	340 000 035
3,80	78	119	3,8	10	070068	340 000 038
3,90	78	119	3,9	10	070327	340 000 039
4,00	78	119	4,0	10	070075	340 000 040
4,10	78	119	4,1	10	070082	340 000 041
4,20	78	119	4,2	10	070099	340 000 042
4,30	82	126	4,3	10	070105	340 000 043
4,50	82	126	4,5	10	070112	340 000 045
4,80	87	132	4,8	10	070129	340 000 048
4,90	87	132	4,9	10	070334	340 000 049
5,00	87	132	5,0	10	070136	340 000 050
5,10	87	132	5,1	10	070341	340 000 051
5,20	87	132	5,2	10	070143	340 000 052
5,50	91	139	5,5	10	070150	340 000 055
5,80	91	139	5,8	10	070174	340 000 058
6,00	91	139	6,0	10	070181	340 000 060
6,50	97	148	6,5	10	070198	340 000 065
7,00	102	156	7,0	10	070204	340 000 070
7,50	102	156	7,5	10	070211	340 000 075
8,00	109	165	8,0	10	070228	340 000 080
8,50	109	165	8,5	10	070235	340 000 085
9,00	115	175	9,0	10	070242	340 000 090
9,50	115	175	9,5	10	070259	340 000 095
10,00	121	184	10,0	10	070266	340 000 100
10,50	121	184	10,5	10	070273	340 000 105
11,00	128	195	11,0	10	070280	340 000 110
11,50	128	195	11,5	10	070297	340 000 115
12,00	134	205	12,0	10	070303	340 000 120

342 HSS DIN 1869, GROUND, EXTRA LONG



DRIVE



EXECUTION

- Profile-ground
- Right-hand cutting, type N
- High-performance high-speed steel
- Long, cylindrical
- 118° conical section
- Diametral tolerance h8
- Point thinning from 3,2 mm Ø

FOR USE IN



APPLICATION

- In all rotary and percussion drilling machines
- In machines for mechanical processing
- Only for rotary use

PACKAGING



Comments

- For drilling extremely deep holes
- Cutting speed and feed rate must not be too high for drill bit stability
- Please ensure swarf is removed frequently and cooling is sufficient
- Other dimensions on request

D Ø mm	L2 mm	L1 mm	d Ø mm		FAN 4016707	
3,00	100	150	3,0	1	130014	342 030 150
3,00	130	190	3,0	1	130021	342 030 190
3,20	105	155	3,2	1	130038	342 032 155
3,20	135	200	3,2	1	130045	342 032 200
3,50	115	165	3,5	1	130052	342 035 165
3,50	145	210	3,5	1	130069	342 035 210
4,00	120	175	4,0	1	130076	342 040 175
4,00	150	220	4,0	1	130083	342 040 220
4,00	190	280	4,0	1	130090	342 040 280
4,20	120	175	4,2	1	130106	342 042 175
4,20	150	220	4,2	1	130113	342 042 220
4,50	125	185	4,5	1	130120	342 045 185
4,50	160	235	4,5	1	130137	342 045 235
5,00	135	195	5,0	1	130144	342 050 195
5,00	170	245	5,0	1	130151	342 050 245
5,00	210	315	5,0	1	130168	342 050 315
5,50	140	205	5,5	1	130175	342 055 205
5,50	180	260	5,5	1	130182	342 055 260
6,00	140	205	6,0	1	130199	342 060 205
6,00	180	260	6,0	1	130205	342 060 260
6,00	225	330	6,0	1	130212	342 060 330
6,50	150	215	6,5	1	130229	342 065 215
6,50	190	275	6,5	1	130236	342 065 275
6,50	235	350	6,5	1	130243	342 065 350
7,00	155	225	7,0	1	130250	342 070 225
7,00	200	290	7,0	1	130267	342 070 290
7,00	250	370	7,0	1	130274	342 070 370
7,50	155	225	7,5	1	130281	342 075 225
8,00	165	240	8,0	1	130298	342 080 240
8,00	210	305	8,0	1	130304	342 080 305
8,00	265	390	8,0	1	130311	342 080 390
8,50	165	240	8,5	1	130328	342 085 240
8,50	210	305	8,5	1	130335	342 085 305
9,00	175	250	9,0	1	130359	342 090 250
10,00	185	265	10,0	1	130380	342 100 265
10,00	235	340	10,0	1	130397	342 100 340
10,00	295	430	10,0	1	130403	342 100 430

344 HSS HOLLOW SECTION DRILL BIT / FACADE DRILL BIT

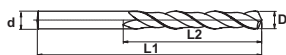

DRIVE



EXECUTION

- Profile-ground
- Right-hand cutting, type N
- High-performance high-speed steel
- Cross ground as per DIN 1412
- Works standard

FOR USE IN



APPLICATION

- In all rotary and percussion drilling machines
- In machines for mechanical processing
- Only for rotary use

PACKAGING



D Ø mm	L2 mm	L1 mm		EAN 4016707...	2345
5,00	30	100	1	230011	344 050 100
5,00	30	150	1	230035	344 050 150
5,00	30	210	1	230059	344 050 210
5,30	30	150	1	230080	344 053 150
5,30	30	180	1	230097	344 053 180
5,30	30	210	1	230103	344 053 210
5,50	30	210	1	230158	344 055 210
5,70	30	100	1	230165	344 057 100
5,70	30	120	1	230172	344 057 120
5,70	30	150	1	230189	344 057 150
5,70	30	180	1	230196	344 057 180
5,70	30	210	1	230202	344 057 210
5,80	30	100	1	230219	344 058 100
5,80	30	120	1	230226	344 058 120
5,80	30	150	1	230233	344 058 150
5,80	30	180	1	230240	344 058 180
5,80	30	210	1	230257	344 058 210

HSS HOLLOW SECTION DRILL BIT / FACADE DRILL BIT

Ideal for drilling in metal sheet and aluminium constructions, sections and pipes, e.g. for assembly of windows, facade substructures or for roofing. No sticking and lower risk of breakage due to short chip flute (30 mm).

345 HSS DIN 345 MORSE TAPER



DRIVE



EXECUTION

- Right-hand cutting, type N
- High-performance high-speed steel
- 118° conical section
- Diametral tolerance h8

FOR USE IN



APPLICATION

- In machines for mechanical processing
- Only for rotary use

PACKAGING



- Hanger with round hole

D Ø mm	L2 mm	L1 mm	MK		EAN 4016707...	 12345
8,00	75	156	1	1	080012	345 000 080
10,00	87	168	1	1	080050	345 000 100
10,50	87	168	1	1	080067	345 000 105
11,00	94	175	1	1	080074	345 000 110
12,00	101	182	1	1	080098	345 000 120
12,50	101	182	1	1	080104	345 000 125
13,00	101	182	1	1	080111	345 000 130
13,50	108	189	1	1	080128	345 000 135
14,00	108	189	1	1	080135	345 000 140
14,50	114	212	2	1	080142	345 000 145
15,00	114	212	2	1	080159	345 000 150
15,50	120	218	2	1	080166	345 000 155
16,00	120	218	2	1	080173	345 000 160
16,50	125	223	2	1	080180	345 000 165
17,00	125	223	2	1	080197	345 000 170
17,50	130	228	2	1	080203	345 000 175
18,00	130	228	2	1	080210	345 000 180
18,50	135	233	2	1	080227	345 000 185
19,00	135	233	2	1	080234	345 000 190
19,50	140	238	2	1	080241	345 000 195
20,00	140	238	2	1	080258	345 000 200
20,50	145	243	2	1	080265	345 000 205
21,00	145	243	2	1	080272	345 000 210
21,50	150	248	2	1	080289	345 000 215
22,00	150	248	2	1	080296	345 000 220
22,50	155	253	2	1	080302	345 000 225
23,00	155	253	2	1	080319	345 000 230
23,50	155	276	3	1	080326	345 000 235
24,00	155	281	3	1	080333	345 000 240
24,50	160	281	3	1	080340	345 000 245
25,00	160	281	3	1	080357	345 000 250
25,50	165	286	3	1	080364	345 000 255
26,00	165	286	3	1	080371	345 000 260
26,50	165	286	3	1	080388	345 000 265
27,00	170	291	3	1	080395	345 000 270
28,00	170	291	3	1	080418	345 000 280
29,00	175	296	3	1	080432	345 000 290
30,00	175	296	3	1	080456	345 000 300
30,50	180	301	3	1	080463	345 000 305
31,00	180	301	3	1	080470	345 000 310
32,00	185	334	4	1	080494	345 000 320
33,00	185	334	4	1	080517	345 000 330

345 HSS DIN 345 MORSE TAPER

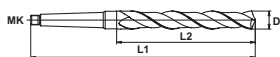

DRIVE



D Ø mm	L2 mm	L1 mm	MK 6		EAN 4016707...	 12345
35,00	190	339	4	1	080555	345 000 350
38,00	200	349	4	1	080616	345 000 380
40,00	200	349	4	1	080654	345 000 400

EXECUTION

- Right-hand cutting, type N
- High-performance high-speed steel
- 118° conical section
- Diametral tolerance h8

FOR USE IN



APPLICATION

- In machines for mechanical processing
- Only for rotary use

PACKAGING



- Hanger with round hole

303 HSS DIN 1897 PILOT DRILL BIT, GROUND, SPLIT POINT, EXTRA SHORT

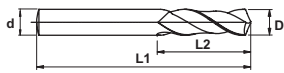

DRIVE



EXECUTION

- Profile-ground
- Right-hand cutting, type N
- Extra short, cylindrical
- High-performance high-speed steel
- 135° conical section
- Cross-ground finish to DIN 1412 C (from \varnothing 3,0 mm)
- Diametral tolerance h8

FOR USE IN



- In thin sheets, steel and cast steel, alloyed and unalloyed, up to a strength of 800 N/mm², cast iron, malleable iron, ductile iron, short chipping aluminium alloys, bronze, tough brass, gunmetal, pressure castings, diecastings
- Keil HSS pilot drill bits to DIN 1897 make it possible to drill a very accurate pilot hole without slipping thanks to the special self-centring drill tip.
- It is not necessary to use a centre punch.
- This extra short drill bit is particularly suited for use with hand-held drills.

APPLICATION

- In all rotary and percussion drilling machines
- In machines for mechanical processing
- Only for rotary use

PACKAGING



D Ø mm	L2 mm	L1 mm	d Ø mm	PKT	FAN 4016707...	ART NO.
2,00	12	38	2,0	10	090011	303 000 200
2,50	14	43	2,5	10	090028	303 000 250
3,00	16	46	3,0	10	090035	303 000 300
3,20	18	49	3,2	10	090059	303 000 320
3,30	18	49	3,3	10	090066	303 000 330
3,50	20	52	3,5	10	090080	303 000 350
4,00	22	55	4,0	10	090134	303 000 400
4,10	22	55	4,1	10	090141	303 000 410
4,20	22	55	4,2	10	090158	303 000 420
4,50	24	58	4,5	10	090189	303 000 450
5,00	26	62	5,0	10	090233	303 000 500
5,10	26	62	5,1	10	090240	303 000 510
5,20	26	62	5,2	10	090257	303 000 520
6,00	28	66	6,0	10	090332	303 000 600
6,50	31	70	6,5	10	090349	303 000 650
8,00	37	79	8,0	10	090370	303 000 800
8,50	37	79	8,5	10	090387	303 000 850

310 HSS DIN 8037 CARBIDE TIPPED

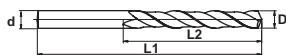

DRIVE



EXECUTION

- Carbide tip according to DIN 8010
- Cutting angle 120°
- Profile-ground
- Right-hand cutting
- Short, cylindrical
- Driver on shaft as per DIN 1809
- Drill body of HSS
- Diametral tolerance h8
- With point thinning

FOR USE IN



- For steel 800-1400 N/mm², cast steel above 700 N/mm², grey cast iron, chill casting, malleable iron, gunmetal, cast steel, tool steel, brass, bronze, manganese steel, cast iron, aluminium, bakelite, hard paper, glass, porcelain and many other special alloys which are difficult to machine

APPLICATION

- In stationary drilling machines
- Only for rotary use

PACKAGING



D ø mm	L2 mm	L1 mm	d ø mm		EAN 4016707...	
2,00	18	45	2,0	1	140013	310 000 020
2,50	18	45	2,5	1	140020	310 000 025
3,00	20	50	3,0	1	140037	310 000 030
3,50	25	56	3,5	1	140044	310 000 035
4,00	25	56	4,0	1	140068	310 000 040
4,20	25	63	4,2	1	140075	310 000 042
4,50	25	63	4,5	1	140082	310 000 045
4,80	25	63	4,8	1	140099	310 000 048
5,00	25	63	5,0	1	140105	310 000 050
5,50	32	71	5,5	1	140136	310 000 055
6,00	32	71	6,0	1	140150	310 000 060
6,50	32	71	6,5	1	140167	310 000 065
7,00	40	80	7,0	1	140181	310 000 070
7,50	40	80	7,5	1	140198	310 000 075
8,00	40	80	8,0	1	140204	310 000 080
8,50	50	90	8,5	1	140211	310 000 085
9,00	50	90	9,0	1	140228	310 000 090
10,00	56	100	10,0	1	140242	310 000 100
11,00	56	100	11,0	1	140259	310 000 110
12,00	63	112	12,0	1	140266	310 000 120
13,00	63	112	13,0	1	140273	310 000 130

HSS DIN 8037 CARBIDE TIPPED

- Ground with diamond wheels to the highest accuracy
- The 2-bevel sharpening of the cutting angle form an exact center which makes the drill bit self centering

Advantages:

- Very precise holes with perfect surface
- Increased drilling length before retraction
- Less wear on the guide edge
- More holes until re-grinding
- High power for drilling with N.C. machines
- No need for drill bushes

312 HSS-G SPEEDER DIN 338 RN METAL DRILL BIT



DRIVE



EXECUTION

- HSS-G quality
- Fully ground helix design
- Aggressive, self-centring W tip

FOR USE IN



APPLICATION

- Ideal for extremely precise work
- Great results in thin steel sheets
- Drills in cast iron, iron, non-ferrous metal, stainless steel and steel
- Ideal for cordless drills or box column drills

PACKAGING



D ø mm	L2 mm	L1 mm	d ø mm	Icon	FAN 4016707...	Icon
3,00	33	61	3	1	919893	312 000 030
3,20	36	65	3,2	1	919909	312 000 032
3,30	36	65	3,3	1	919916	312 000 033
3,50	39	70	3,5	1	919923	312 000 035
4,00	43	75	4	1	919930	312 000 040
4,20	43	75	4,2	1	919947	312 000 042
4,50	47	80	4,5	1	929954	312 000 045
4,80	52	86	4,8	1	919961	312 000 048
5,00	52	86	5	1	919985	312 000 050
5,50	57	93	5,5	1	919992	312 000 055
6,00	57	93	6	1	920004	312 000 060
6,50	63	101	6,5	1	920011	312 000 065
7,00	69	109	7	1	920028	312 000 070
7,50	69	109	7,5	1	920035	312 000 075
8,00	75	117	8	1	920042	312 000 080
8,50	75	117	8,5	1	920059	312 000 085
9,00	81	125	9	1	920066	312 000 090
9,50	81	125	9,5	1	920073	312 000 095
10,00	87	133	10	1	920080	312 000 100
10,50	87	133	10,5	1	920097	312 000 105
11,00	94	142	11	1	920103	312 000 110
11,50	94	142	11,5	1	920110	312 000 115
12,00	101	151	12	1	920127	312 000 120
12,50	101	151	12,5	1	920134	312 000 125
13,00	101	151	13	1	920141	312 000 130

HSS-G DIN 338

- Centre punching is not necessary
- Safe pilot hole drilling, even in slanting surfaces, in pipes and welds
- The feeding power is reduced by up to 50 %
- The drill bit facilitates an increase in drilling progress by up to 45 %
- Regular chip removal and reduction of chip friction
- Extremely true running and precise round holes
- No jamming of the main cutting edge and no slipping of the drill bit for through-holes
- High fracture strength and long life
- Reduced friction due to reduced external diameter in shank direction
- Higher breaking resistance due to conically reinforced drilling core
- Long operating time and fast drilling progress due to chemical thermal method of hardening and accurate cross-ground finish

304 HSS DOUBLE-END DRILL BIT, GROUND, SPLIT POINT

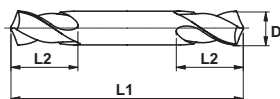

DRIVE



D Ø mm	L2 mm	L1 mm		EAN 4016707...	
3,00	10	46	10	100017	304 000 300
3,10	10	46	10	100024	304 000 310
3,20	10	49	10	100031	304 000 320
3,30	10	49	10	100048	304 000 330
3,50	13	52	10	100062	304 000 350
4,00	13	55	10	100086	304 000 400
4,10	13	55	10	100093	304 000 410
4,20	13	55	10	100109	304 000 420
4,50	16	58	10	100123	304 000 450
4,80	16	58	10	100130	304 000 480
5,00	16	62	10	100147	304 000 500
5,10	16	62	10	100154	304 000 510
5,20	16	62	10	100161	304 000 520

EXECUTION

- Double-ended, right-hand cutting, type N, works standard
- High-performance high-speed steel
- 118° conical section
- Diametral tolerance h8
- Profile-ground
- Cross-ground finish to DIN 1412 C

FOR USE IN



- For drilling thin sheets for car bodies and metal fabrication, for rivet holes, screw holes etc., in steel, zinc, brass, aluminium, copper sheet and plastic panels

APPLICATION

- In all rotary and percussion drilling machines
- In machines for mechanical processing
- Only for rotary use

PACKAGING



315 HSS BIT DRILL KEILBIT, GROUND

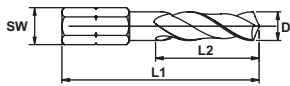

DRIVE



EXECUTION

- Profile-ground
- Right-hand cutting, type N
- High-performance high-speed steel
- Short, cylindrical
- 118° conical section
- Diametral tolerance h8
- 1/4" bit drive DIN 3126 - C 6.3

FOR USE IN



APPLICATION

- In all rotary and percussion drilling machines
- In machines for mechanical processing
- Only for rotary use
- In all drilling machines, cordless screw drivers and bit holders with 1/4" drill shank
- SDS-plus locating shank for Bits and KEILBIT [37]
- Quick bit holder for bits and KEILBIT [72]

PACKAGING



[154]

D Ø mm	L2 mm	L1 mm	SW mm	Icon	FAN 4016707...	Icon	12345
2,00	30	50	6,35	1	105074		315 000 200
2,50	30	50	6,35	1	105081		315 000 250
3,00	30	50	6,35	1	105005		315 000 300
3,30	30	50	6,35	1	105098		315 000 330
3,50	30	50	6,35	1	105104		315 000 350
4,00	30	50	6,35	1	105012		315 000 400
4,20	30	50	6,35	1	105111		315 000 420
4,50	30	50	6,35	1	105128		315 000 450
5,00	30	50	6,35	1	105029		315 000 500
5,50	30	50	6,35	1	105135		315 000 550
6,00	30	50	6,35	1	105036		315 000 600
6,50	30	50	6,35	1	105142		315 000 650
6,80	35	55	6,35	1	105159		315 000 680
7,00	35	55	6,35	1	105166		315 000 700
7,50	35	55	6,35	1	105173		315 000 750
8,00	35	55	6,35	1	105043		315 000 800
8,50	35	55	6,35	1	105180		315 000 850
9,00	35	55	6,35	1	105197		315 000 900
10,00	35	55	6,35	1	105050		315 001 000
10,20	35	55	6,35	1	105210		315 001 020

HSS BIT DRILL KEILBIT, GROUND

- Modern cordless screw drivers are extremely efficient and can also be used for drilling without any problems. The KEILBIT was particularly developed for quick direct application in these machines.
- Machine changing is not necessary anymore.
- For drilling other materials we offer various types of KEILBIT.

317 HSS COMBINATION TOOL KEILBIT

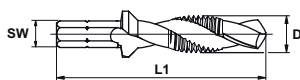

DRIVE



D Ø mm	L1 mm	SW mm	M		EAN 4016707...	12345
2,50	36	6,35	3	1	150319	317 000 030
3,30	39	6,35	4	1	150326	317 000 040
4,20	41	6,35	5	1	150333	317 000 050
5,00	44	6,35	6	1	150340	317 000 060
6,80	50	6,35	8	1	150357	317 000 080
8,50	59	6,35	10	1	150364	317 000 100

EXECUTION

- Profile-ground with cross-ground finish
- High-performance high-speed steel
- 1/4" bit drive DIN 3126 - C 6.3

FOR USE IN



APPLICATION

- Up to max. 600 N/mm²
- In all rotary and percussion drilling machines
- n machines for mechanical processing
- Only for rotary use
- In all drilling machines, cordless screw drivers and bit holders with 1/4" drill shank
- SDS-plus locating shank for Bits and KEILBIT [37]
- Quick bit holder for bits and KEILBIT [72]

PACKAGING

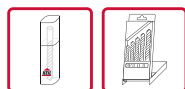

[154]

Comments

- Material not thicker than 1 x D (e.g.: M 6 = 6 mm material thickness)

HSS COMBINATION TOOL KEILBIT

In one step:

- Drilling
- Tapping
- Deburring

Innovations:

- Optimal centring
- Low feedpower
- Better swarf removal
- Easier cutting
- Low torque
- Low cant-risk
- Better return guiding
- High bending and torsional elasticity
- Reduced risk of breakage
- Forgiving of incorrect use

329 HSS COUNTERSINK 90° KEILBIT

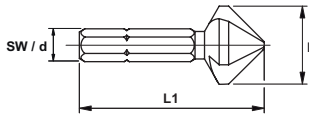

DRIVE



D ø mm	L1 mm	SW mm	d ø mm	M	Icons	EAN 4016707...	12345
6,30	31	6,35	6,3	3	1	150388	329 000 063
8,30	31	6,35	6,3	4	1	150395	329 000 083
10,40	34	6,35	6,3	5	1	150401	329 000 104
12,40	35	6,35	6,3	6	1	150418	329 000 124
16,50	40	6,35	6,3	8	1	150425	329 000 165
20,50	41	6,35	6,3	10	1	150432	329 000 205

EXECUTION

- Cutting head according to DIN 335 C
- 1/4" bit drive DIN 3126 - C 6.3
- 3 cutting edges
- Radial and axial relief

FOR USE IN



- Deburring and drilling of uniformly circular counter sink holes with a smooth surface
- Suitable for almost all materials
- The best results are obtained at low speeds and a high feedrate

APPLICATION

- In all rotary and percussion drilling machines
- In machines for mechanical processing
- Only for rotary use
- In all drilling machines, cordless screw drivers and bit holders with 1/4" drill shank
- SDS-plus locating shank for Bits and KEILBIT [37]
- Quick bit holder for bits and KEILBIT [72]

PACKAGING

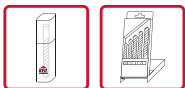

[154]

Comments

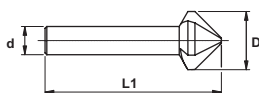

- Individual packaging with hanger

327 HSS COUNTERSINK 90° DIN 335 C



DRIVE



D Ø mm	L1 mm	d Ø mm	M		EAN 4016707...	 12345
6,30	45	5,0	3	1	150142	327 000 063
8,30	50	6,0	4	1	150159	327 000 083
10,40	50	6,0	5	1	150166	327 000 104
12,40	56	8,0	6	1	150173	327 000 124
16,50	60	10,0	8	1	150180	327 000 165
20,50	63	10,0	10	1	150197	327 000 205
25,00	67	10,0	12	1	150203	327 000 250

EXECUTION

- DIN 335 C, with cylindrical shank
- 3 cutting edges
- CBN profile ground
- Radial and axial relief
- Right-hand cutting
- Diametral tolerance h8

FOR USE IN



- Deburring and drilling of uniformly circular counter sink holes with a smooth surface
- Suitable for almost all materials
- The best results are obtained at low speeds and a high feedrate

APPLICATION

- In all rotary and percussion drilling machines
- In machines for mechanical processing
- Only for rotary use

PACKAGING



[154]

Comments

- Up to Ø 20,5 mm individual packaging with round hole
- From Ø 25,0 mm individual packaging with Euro hole

328 HSS DEBURRING COUNTERSINK 90° WITH CROSS HOLE

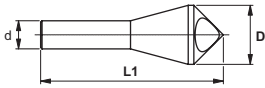

DRIVE



D Ø mm	L1 mm	d Ø mm		EAN 4016707...	
2,0 - 5,0	45	6,0	1	150227	328 020 050
5,0 - 10,0	48	8,0	1	150234	328 050 100
10,0 - 15,0	65	10,0	1	150241	328 100 150
15,0 - 20,0	84	12,0	1	150258	328 150 200

EXECUTION

- Countersinking angle 90°, with cylindrical shank to works standard
- High-performance high-speed steel

FOR USE IN



- Easy deburring of holes without vibration
- One step countersinking and deburring
- Suitable for soft long-chipping materials

APPLICATION

- In all rotary and percussion drilling machines
- In machines for mechanical processing
- Only for rotary use

PACKAGING

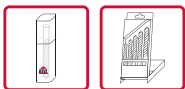

[154]

Comments

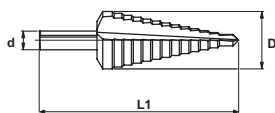

- Up to Ø 10,0 - 15,0 mm individual packaging with Euro hole
- From Ø 15,0 - 20 mm individual packaging with Euro hole

326 HSS TUBE & SHEET DRILL



EXECUTION

- CBN profile ground
- Right-hand cutting
- High-performance high-speed steel
- Laser marking
- Two cutters
- Conical drilling
- Centering tip

No	D ø mm	L1 mm	d ø mm		EAN 4016707...	 12345
1	3,0 - 14,0	58	6,0	1	150067	326 030 140
2	4,0 - 20,0	71	8,0	1	150074	326 060 200
3	16,0 - 30,5	76	9,0	1	150081	326 160 305
4	24,0 - 40,0	89	10,0	1	150098	326 240 400
5	36,0 - 50,0	97	12,0	1	150104	326 360 500
6	4,0 - 31,0	103	9,0	1	150128	326 040 310

FOR USE IN



- For drilling large holes in thin material and reborng existing holes
- Steel sheet and stainless steel from 0.1 to 2 mm thick
- Non-ferrous metals from 0.1 to 5 mm thick
- Plastic up to 10 mm thick

APPLICATION

- In all rotary and percussion drilling machines
- In machines for mechanical processing
- Only for rotary use

PACKAGING

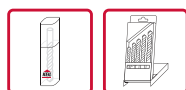

[154]

Comments

- Up to No. 2 individual packaging with round hole
- From No. 3 individual packaging with Euro hole

325 HSS STEP DRILLS

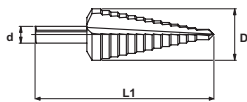

EXECUTION

- CBN profile ground
- Right-hand cutting
- High-performance high-speed steel
- Laser marking
- Two cutters

No	D ø mm		L1 mm	d ø mm		EAN 4016707...	
1	4,0 - 12,0	1	80	6,0	1	150012	325 040 120
2	4,0 - 20,0	2	67	8,0	1	150029	325 040 200
3	6,0 - 30,0	2	98	10,0	1	150036	325 060 300
4	9,0 - 36,0	3	80	12,0	1	150043	325 090 360
5	7,0 - 32,5		96	6,0	1	150005	325 070 325

FOR USE IN



APPLICATION

- For drilling large holes in thin material and reboring existing holes
- Steel sheet and stainless steel from 0.1 to 2 mm thick
- Non-ferrous metals from 0.1 to 5 mm thick
- Plastic up to 10 mm thick

PACKAGING

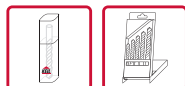

[154]

Comments

- Up to No. 2 individual packaging with round hole
- From No. 3 individual packaging with Euro hole

HSS STEP DRILL

- Straight flute
- Cylindrical drilling

For electricians:

- Spiral shaped flute for electricians for the use of cable screw connections according to latest European standard DIN EN 60423
- Applicable for thread and core holes into service cabinets with max. 5,5 mm wall depth

HSS step drills for electricians Drilling region for cable screw connections



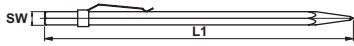

	M	d ø mm	d ø mm	d ø mm	d ø mm	d ø mm	
Cable connection		M 12x1,5	M 16x1,5	M 20x1,5	M 25x1,5	M 32x1,5	
Thread core hole	ø 7	10,5	14,5	18,5	23,5	30,5	6mm
Through-hole	ø 7	12,5	16,5	20,5	25,5	32,5	3mm

140 SCRIBER



EXECUTION

- With carbide tip
- Chromated surface

L1  mm	SW  mm		EAN  4016707...	 12345
140	6,00	10	010101	140 140 060

FOR USE IN



PACKAGING



320 HSS HOLE SAW BI-METAL

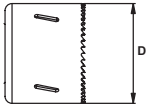

EXECUTION

- Variable tooth splitting for less vibration
- Less heat production
- Long life
- High precision of concentric running
- Smoother cutting
- Cutting depth up to max. 38 mm
- Up to Ø 30 mm R 1/4" thread
- Up to Ø 32 mm R 3/8" thread
- R = pipe thread

FOR USE IN



- For iron, steel, nonferrous heavy metal, light alloy, cast iron, plastics, wood, plywood, plaster board

APPLICATION

- In all rotary and percussion drilling machines
- In machines for mechanical processing
- Pillar drilling machines or lathes
- Only for rotary use

PACKAGING



[155]

[166]

Comments

- 1 = Recommended speed - Wrought Steel
- 2 = Recommended speed - Cast iron
- 3 = Recommended speed - Stainless Steel
- 4 = Recommended speed - Copper Brass
- 5 = Recommended speed - Aluminium

D Ø mm	D Ø "	1 2/min	2 2/min	3 2/min	4 2/min	5 2/min		EAN 4016707	
14,0	9/16	580	400	300	790	900	1	110016	320 000 014
16,0	5/8	550	365	275	730	825	1	110023	320 000 016
17,0	11/16	500	330	250	665	750	1	110030	320 000 017
19,0	3/4	460	300	230	600	690	1	110047	320 000 019
20,0	25/32	440	290	220	580	660	1	110054	320 000 020
21,0	13/16	425	280	210	560	635	1	110061	320 000 021
22,0	7/8	390	260	195	520	585	1	110078	320 000 022
24,0	15/16	370	245	185	495	555	1	110085	320 000 024
25,0	1	350	235	175	470	525	1	110092	320 000 025
27,0	11/16	325	215	160	435	480	1	110108	320 000 027
29,0	1 1/8	300	200	150	400	450	1	110115	320 000 029
30,0	1 3/16	285	190	145	380	425	1	110122	320 000 030
32,0	1 1/4	275	180	140	380	410	1	110139	320 000 032
33,0	1 5/16	260	175	135	345	390	1	110146	320 000 033
35,0	1 3/8	250	165	125	330	375	1	110153	320 000 035
37,0	1 7/16	240	160	120	315	360	1	110160	320 000 037
38,0	1 1/2	230	150	115	300	345	1	110177	320 000 038
40,0	1 9/16	220	145	110	290	330	1	110184	320 000 040
41,0	1 5/8	210	140	105	280	315	1	110191	320 000 041
43,0	1 11/16	205	135	100	270	305	1	110207	320 000 043
44,0	1 3/4	195	130	95	260	295	1	110214	320 000 044
45,0	1 25/32	190	125	95	250	285	1	110719	320 000 045
46,0	1 13/16	190	125	95	250	285	1	110221	320 000 046
48,0	1 7/8	180	120	90	240	270	1	110238	320 000 048
50,0	1 31/32	170	115	85	230	255	1	110726	320 000 050
51,0	2	170	115	85	230	255	1	110245	320 000 051
52,0	2 1/16	165	110	80	220	245	1	110252	320 000 052
54,0	2 1/8	160	105	80	210	240	1	110269	320 000 054
55,0	2 3/16	150	100	75	200	225	1	110733	320 000 055
57,0	2 1/4	150	100	75	200	225	1	110276	320 000 057
59,0	2 5/16	145	100	75	195	225	1	110283	320 000 059
60,0	2 3/8	140	95	70	190	220	1	110290	320 000 060
64,0	2 1/2	135	90	65	180	205	1	110306	320 000 064
65,0	2 9/16	130	85	65	175	200	1	110313	320 000 065
67,0	2 5/8	130	85	65	170	195	1	110320	320 000 067
68,0	2 11/16	125	80	60	160	185	1	110337	320 000 068
70,0	2 3/4	125	80	60	160	185	1	110344	320 000 070
73,0	2 7/8	120	80	60	160	180	1	110351	320 000 073
75,0	2 31/32	115	75	55	150	170	1	110740	320 000 075
76,0	3	115	75	55	150	170	1	110368	320 000 076
79,0	3 1/8	110	70	55	140	165	1	110375	320 000 079
83,0	3 1/4	105	70	50	140	155	1	110382	320 000 083
86,0	3 3/8	100	65	50	130	150	1	110399	320 000 086
89,0	3 1/2	95	65	65	130	145	1	110405	320 000 089
92,0	3 5/8	95	60	60	120	140	1	110412	320 000 092
95,0	3 3/4	90	60	60	120	133	1	110429	320 000 095

320 HSS HOLE SAW BI-METAL

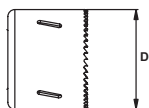

EXECUTION

- Variable tooth splitting for less vibration
- Less heat production
- Long life
- High precision of concentric running
- Smoother cutting
- Cutting depth up to max. 38 mm
- Up to $\varnothing 30$ mm R 1/4" thread
- Up to $\varnothing 32$ mm R 3/8" thread
- R = pipe thread

FOR USE IN



- For iron, steel, nonferrous heavy metal, light alloy, cast iron, plastics, wood, plywood, plaster board

APPLICATION

- In all rotary and percussion drilling machines
- In machines for mechanical processing
- Pillar drilling machines or lathes
- Only for rotary use

PACKAGING



[155]

[166]

Comments

- 1 = Recommended speed - Wrought Steel
- 2 = Recommended speed - Cast iron
- 3 = Recommended speed - Stainless Steel
- 4 = Recommended speed - Copper Brass
- 5 = Recommended speed - Aluminium

\varnothing mm	\varnothing "	1 2/min	2 2/min	3 2/min	4 2/min	5 2/min	Box	EAN 4016707...	12345
98,0	3 7/8	90	60	45	120	135	1	110436	320 000 098
102,0	4	85	55	40	110	130	1	110443	320 000 102
105,0	4 1/8	80	55	40	110	120	1	110450	320 000 105
108,0	4 1/4	80	55	40	110	120	1	110467	320 000 108
111,0	4 3/8	80	50	40	100	120	1	110474	320 000 111
114,0	4 1/2	75	50	35	100	105	1	110481	320 000 114
121,0	4 3/4	75	50	35	95	95	1	110498	320 000 121
127,0	5	65	45	30	90	90	1	110504	320 000 127
140,0	5 1/2	60	40	25	85	85	1	110511	320 000 140
146,0	5 3/4	55	35	25	75	75	1	110528	320 000 146
152,0	6	55	35	25	75	75	1	110535	320 000 152

LOCATING SHANK FOR BI-METAL HOLE SAW



No	SW mm	d \varnothing mm	Box	EAN 4016707...	12345	
1		6,3	LS 14-30	1	110580	320 300 006
2	9,50		LS 14-30	1	110597	320 300 095
3	11,00		LS 14-30	1	110603	320 300 011
4	SDS-plus		LS 14-30	1	110696	320 255 001
5	9,50		LS 32-152	1	110627	320 400 095
6	11,00		LS 32-152	1	110610	320 301 011
7	11,00		LS 32-152	1	110634	320 400 011
8	16,00		LS 32-152	1	110641	320 400 016
9	SDS-plus		LS 32-152	1	110702	320 255 002

CENTRE DRILL BIT FOR BI-METAL HOLE SAW



L1 mm	d \varnothing mm	Box	EAN 4016707...	12345	
75	6,3	Chuck 2-3-4-5-6-7-9	1	110658	320 100 080
105	6,3	Chuck 1-8	1	110665	320 100 115

LOCATING SHANK FOR BI-METAL HOLE SAW



L1 mm	SW mm	Box	EAN 4016707...	12345	
300	11,00	Chuck 3-6-7	1	110689	320 500 100

HSS HOLE SAW BI-METAL



PRODUCT INFORMATION:

- Designed for long lifetime and high cutting performance
- Always use the recommended operating speed, speed to be increased slowly till a slight cutting is noticed; to avoid overheating, abrasive or breaking out of cutting teeth.
- When drilling in metals (except cast iron) always use sufficient cutting-oil
- Remove regularly drilling chips from the cutting spiral
- Do not use high working pressure and assure that the saw does really cut.
- The centre drill must exceed the saw teeth by approximate 3 - 4 mm but no more than the thickness of the workpiece
- Make sure that the hole saw always is in vertical position to the work piece surface

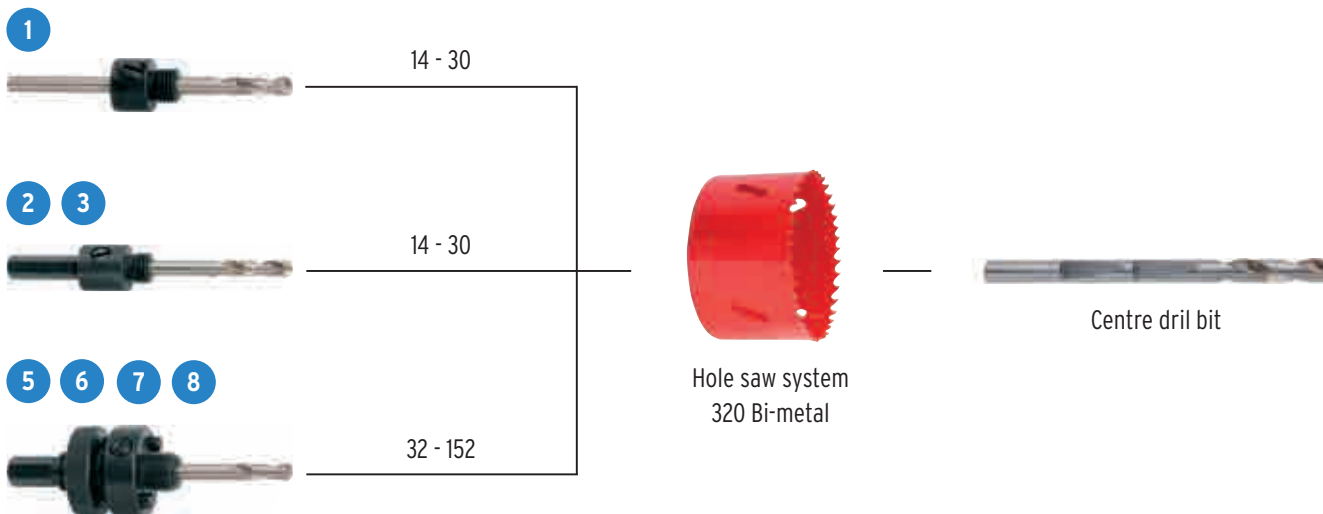

Item numbers for locating shanks of various hole saw manufacturers

Keil	American SAW	MILFORD	Milwaukee	RULE	SANDVIK	STARRETT	MORSE
320 300 006	4 L	45136	49-56 6950	5514	3834-0630	A4	M 24 K
320 300 095	5 L	45319				A1	M 34
320 300 011	1 L	45313	49-56 7000	5518	3834-1130	A11	M 44
320 400 016	2 L	45315	49-56 7130	5573	3834-16152	A3	M 55 P
320 400 011	2 L	45314		5545	3834-11152		M 45 P

HSS HOLE SAW BI-METAL





WORKING CONDITIONS:

- Incorrect technical working conditions frequently lead to breakage of the drill bit or to premature wear of the drilling tool.
- Our speed table gives recommendations on cutting speeds and feed rates.
- Depending on the actual working conditions it may, however, be necessary to determine individual cutting values by means of tests.
- The cutting values should be reduced by 20 to 40 per cent for horizontal holes and for drilling depths which are five times larger than the hole diameter ($5 \times \varnothing$).

DO NOT OVERHEAT DRILL BIT:

- High-alloy and heat-resistant materials can only be properly cut with the use of coolants, with special cutting oils forming a tightly adhering lubricating film in the cutting zone.
- A cooling emulsion is usually sufficient for normal steel or materials with a low tendency to adhesion. Materials forming short chips, such as brass and cast iron, but also plastics, should be machined without coolant.
- The drill must be briefly lifted off from time to time so that the coolant can penetrate properly into the hole.
- In particular, this must be observed for holes which are three times deeper than the diameter ($3 \times \varnothing$). This also ensures that the flutes can clear out the chips.

Guidelines for the drilling of pilot holes for threaded holes, depending on thread quality required for thread drill bit \varnothing .

M	D
	
3	2,4 - 2,5
4	3,2 - 3,3
5	4,0 - 4,2
6	4,8 - 5,0
8	6,4 - 6,8
10	7,9 - 8,5
12	9,6 - 10,2

CORRECT RE-GRINDING:

- The correct tip grind of a drill bit is the basic condition for economic drilling. Thus timely re-grinding and, in particular, grinding to the correct shape of the cutting edges is essential for uninterrupted production.
- KEIL recommends re-grinding with one of the tip grinding machines for twist drill bits available in the market, as only these machines ensure the setup for optimum re-grinding of the main cutters, cutter corners, land and chisel edges.
- Manual regrinding is not recommended as this is too imprecise, leads to early nonrecoverable wear of the drill bits and does not allow accurate holes to be drilled.

TECHNICAL INFORMATION HSS DRILL BITS

Inch fraction	Inch decimal	mm
1/64"	0,015625"	0,397
1/32"	0,03125"	0,794
3/64"	0,046875"	1,191
1/16"	0,0625"	1,588
5/64"	0,078125"	1,984
3/32"	0,09375"	2,381
7/64"	0,109375"	2,778
1/8"	0,125"	3,175
9/64"	0,140625"	3,572
5/32"	0,15625"	3,969
11/64"	0,171875"	4,366
3/16"	0,1875"	4,763
13/64"	0,203125"	5,159
7/32"	0,21875"	5,556
15/64"	0,234375"	5,953
1/4"	0,25"	6,350
17/64"	0,265625"	6,747
9/32"	0,28125"	7,144
19/64"	0,296875"	7,541
5/16"	0,3125"	7,938
21/64"	0,328125"	8,334
11/32"	0,34375"	8,731
23/64"	0,359375"	9,128
3/8"	0,375"	9,525
25/64"	0,390625"	9,922
13/32"	0,40625"	10,319
27/64"	0,421875"	10,716
7/16"	0,4375"	11,113
29/64"	0,453125"	11,509
15/32"	0,46875"	11,906
31/64"	0,484375"	12,303
1/2"	0,5"	12,700
33/64"	0,515625"	13,097
17/32"	0,53125"	13,494
35/64"	0,546875"	13,891
9/16"	0,5625"	14,288
37/64"	0,578125"	14,684
19/32"	0,59375"	15,081
39/64"	0,609375"	15,478
5/8"	0,625"	15,875
41/64"	0,640625"	16,272
21/32"	0,65625"	16,669
43/64"	0,671875"	17,066
11/16"	0,6875"	17,463
45/64"	0,703125"	17,859
23/32"	0,71875"	18,256
47/64"	0,734375"	18,653
3/4"	0,75"	19,050

Inch fraction	Inch decimal	mm
49/64"	0,765625"	19,447
25/32"	0,78125"	19,844
51/64"	0,796875"	20,241
13/16"	0,8125"	20,638
53/64"	0,828125"	21,034
27/32"	0,84375"	21,431
55/64"	0,859375"	21,828
7/8"	0,875"	22,225
57/64"	0,890625"	22,622
29/32"	0,90625"	23,019
59/64"	0,921875"	23,416
15/16"	0,9375"	23,813
61/64"	0,953125"	24,209
31/32"	0,96875"	24,606
63/64"	0,984375"	25,003
1"	1"	25,400
11/64"	1,015625"	25,797
11/32"	1,03125"	26,194
13/64"	1,046875"	26,591
11/16"	1,0625"	26,988
15/64"	1,078125"	27,384
13/32"	1,09375"	27,781
17/64"	1,109375"	28,178
11/8"	1,125"	28,575
19/64"	1,140625"	28,972
15/32"	1,15625"	29,369
111/64"	1,171875"	29,766
13/16"	1,1875"	30,163
113/64"	1,203125"	30,559
17/32"	1,21875"	30,956
115/64"	1,234375"	31,353
11/4"	1,25"	31,750
117/64"	1,265625"	32,147
19/32"	1,28125"	32,544
119/64"	1,296875"	32,941
15/16"	1,3125"	33,338
121/64"	1,328125"	33,734
111/32"	1,34375"	34,131
123/64"	1,359375"	34,528
13/8"	1,375"	34,925
125/64"	1,390625"	35,322
112/32"	1,40625"	35,719
127/64"	1,421875"	36,116
17/16"	1,4375"	36,513
129/64"	1,453125"	36,909
115/32"	1,46875"	37,306
131/64"	1,484375"	37,703
11/2"	1,5"	38,100

Inch fraction	Inch decimal	mm
133/64"	1,515625"	38,497
117/32"	1,53125"	38,894
135/64"	1,546875"	39,291
19/16"	1,5625"	39,688
137/64"	1,578125"	40,084
119/32"	1,59375"	40,481
139/64"	1,609375"	40,878
15/8"	1,625"	41,275
141/64"	1,640625"	41,672
121/32"	1,65625"	42,069
143/64"	1,671875"	42,466
111/16"	1,6875"	42,863
145/64"	1,703125"	43,259
123/32"	1,71875"	43,656
147/64"	1,734375"	44,053
13/4"	1,75"	44,450
149/64"	1,765625"	44,847
125/32"	1,78125"	45,244
151/64"	1,796875"	45,641
113/16"	1,8125"	46,038
153/64"	1,828125"	46,434
127/32"	1,84375"	46,831
155/64"	1,859375"	47,228
17/8"	1,875"	47,625
157/64"	1,890625"	48,022
129/32"	1,90625"	48,419
159/64"	1,921875"	48,816
115/16"	1,9375"	49,213
161/64"	1,953125"	49,609
131/32"	1,96875"	50,006
163/64"	1,984375"	50,403
2"	2"	50,800

HAMMER DRILL BITS

CHISELS

STONE AND
SPECIAL DRILL BITS

METAL DRILL BITS

WOOD DRILL BITS

SAWS

ASSORTMENTS

MODULES



Twist drill bits with cylindrical shank/taper shank

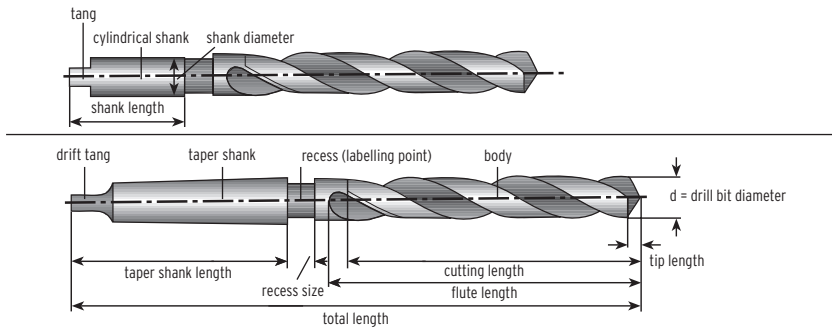

Angles at the cutting edges

The cutting plane has been taken as the cutting point viewed.

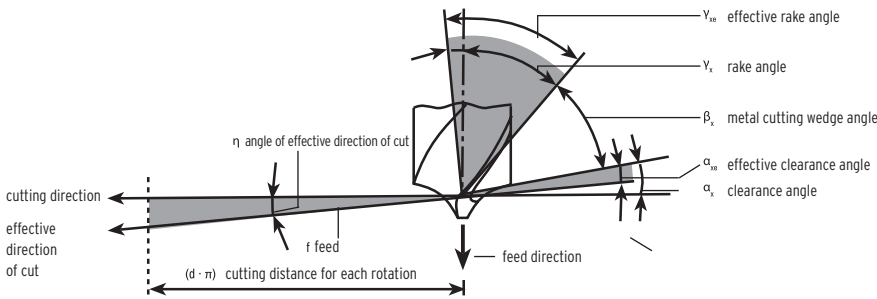

body

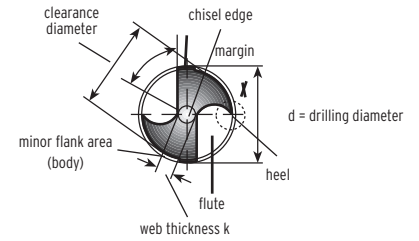
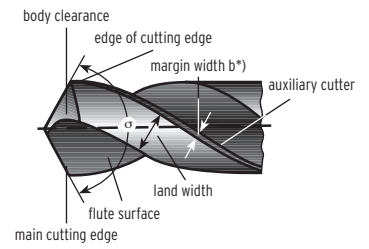

chisel edge angle (Psi)
tip angle (Sigma)

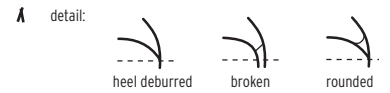

Excerpt from DIN 1412 (issue 12/66)

Speed table - guide values for Keil HSS twist drill bits

Material	Drill bit	Drill bit type	Tip angle quality	Coolant	Cutting speed m/min	Average rpm Feed s (mm/rotation) for bit dia.								
						2	5	8	12	16	25	40	63	80
Free-cutting steel (S.P.-PB alloy) up to 50 kgf/mm ²	N	HSS	118°	Emulsion	30 - 50	5.600 0,05	2.250 0,12	1.400 0,20	930 0,25	700 0,30	450 0,40	280 0,50	180 0,50	160
Unalloyed mild steel up to 50 kgf/mm ²	N	HSS	118°	Emulsion	30 - 40	5.600 0,05	2.250 0,12	1.400 0,20	930 0,25	700 0,30	450 0,40	280 0,40	180 0,50	140 0,60
Unalloyed mild steel 50 - 70 kgf/mm ²	N	HSS	118°	Emulsion	25 - 35	4.750 0,05	1.900 0,12	1.200 0,20	800 0,25	600 0,30	400 0,40	240 0,40	180 0,50	120 0,60
Unalloyed mild steel 70 - 90 kgf/mm ²	N	HSS	118°	Emulsion	10 - 15	2.100	860 0,07	540 0,10	360 0,16	270 0,20	170 0,25	110 0,32	68 0,40	50 0,50
Unalloyed mild steel up to 70 kgf/mm ²	N	HSS	118°	Emulsion	20 - 30	3.980 0,03	1.580 0,07	995 0,10	665 0,16	495 0,20	320 0,25	200 0,32	125 0,40	100 0,50
Alloyed cast steel	N	HSS	118°	Emulsion (oil)	10 - 20	2.380 0,02	950 0,05	595 0,08	400 0,12	300 0,14	190 0,18	120 0,23	75 0,27	60 0,32
Alloyed steel 70 - 90 kgf/mm ²	N	HSS	118°	Emulsion	10 - 15	2.100 0,02	860 0,05	540 0,08	360 0,12	270 0,14	170 0,18	110 0,23	68 0,27	50 0,32
Alloyed Cr-Ni steel 90 - 110 kgf/mm ²	N	HSS	118°	Emulsion (oil)	8 - 12	1.590 0,02	635 0,05	400 0,08	265 0,12	200 0,14	125 0,18	80 0,23	50 0,27	40 0,32
Cast iron up to 200 HB	N	HSS	118°	Dry Comp. air	15 - 25	3.185 0,05	1.265 0,12	795 0,20	530 0,25	400 0,30	255 0,40	160 0,40	100 0,50	80 0,60
Cast iron up to 350 HB (white iron)	N	HSS	118°	Dry Comp. air	5 - 15	1.590 0,03	635 0,07	400 0,10	265 0,16	200 0,20	165 0,25	80 0,32	50 0,40	40 0,50
Nickel Monell metal	N	HSS	118°	Emulsion (oil)	10 - 15	2.100 0,02	860 0,05	540 0,08	360 0,12	270 0,14	170 0,18	110 0,23	68 0,27	50 0,32
Gunmetal, bronze (soft)	N	HSS	118°	Emulsion (oil)	20 - 40	4.745 0,05	1.900 0,08	1.193 0,14	795 0,20	595 0,25	380 0,30	240 0,40	150 0,50	120 0,60
Alu bronze (semi-hard, hard)	N	HSS	118°	Emulsion (oil)	15 - 35	3.980 0,05	1.585 0,08	995 0,14	665 0,20	495 0,25	320 0,30	200 0,40	125 0,50	100 0,60

Comments: These guide values apply to drilling depths of about 3 - 4 times the drill bit diameter. For greater drilling depths, the cutting speed and feed rate must be reduced. In case of very deep holes under severe working conditions, the cutting values must be determined by tests.

OVERVIEW OF 1/4 " HEXAGONAL SHAFT TOOLS



- 1
- 2
- 3

PERCUSSION DRILL

- 1 Glass drill bit KEILBIT
- 2 Universal drill bit KEILBIT
- 3 Quick bit holder for bits and KEILBIT



- 1
- 2
- 3

METAL DRILL BITS

- 1 HSS bit drill KEILBIT, ground
- 2 HSS combination tool KEILBIT
- 3 HSS countersink 90° KEILBIT



- 1
- 2
- 3

WOOD DRILL BITS

- 1 Wood twist drill bit KEILBIT
- 2 Flat bit KEILBIT
- 3 Extension for flat bit KEILBIT

WOOD DRILL BITS



180 280 Wood twist drill bit	119-120
186 HSS wood twist drill bit	121
187 Wood twist drill bit KEILBIT	122
181 Auger bit lewis shape	123
182 Auger drill bit lewis shape with SDS-plus shaft	124
183 Machine forstner bit	125
185 Flat bit KEILBIT	126
185 Extension for flat bit KEILBIT	127
350 Drill bit for timbering, round shank	128
355 SDS-plus drill bit for timbering	129

WOOD DRILL BITS

Professional wood drill bits make perfect holes in all kinds of wood

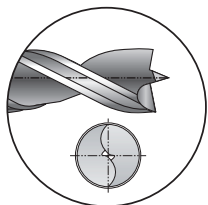

WOOD TWIST DRILL BIT

The double chamfer allows an exact lead in the drilling hole, also in low drilling depths and prevents sticking of chips between drill bit and hole walls. These drill bits are particularly suitable for drilling plug holes and for drilling fibre board, ply wood, pine, beech, oak and similar soft and hard wood. The precisely ground shoulder cutting edges make cylindrical, tear-free holes.

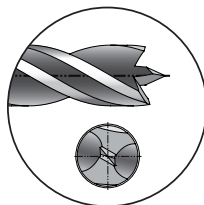

HSS WOOD TWIST DRILL BIT

Made of HSS steel. The specialist for bankirai: Due to its special geometry of grooves and the optimal chip flow our HSS wood twist drill bit is very much suitable for boring in hard and tropical wood as well as laminated boards and plastics.

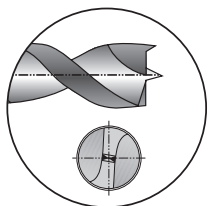

AUGER BIT LEWIS SHAPE

The auger bit has a thread tip, a pre-cutter and a hexagonal shaft. It has a milled and surface ground flute and allows exact and precise drilling in veneered wooden boards as well as all natural soft and hard woods.

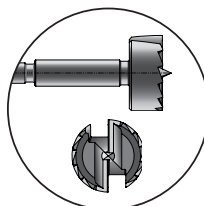

MACHINE FORSTNER DRILL BIT

This drill bit is made from special steel and ground mechanically to its cylindrical shape. Only a very low contact pressure is needed. It has a very good drilling progress and a long tool life. Moreover the power consumption is very low.

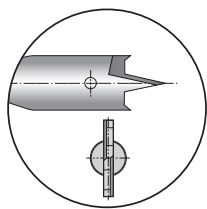

FLAT BITS

Due to its fast and easy tool changing the flat bit is ideal for the DIY-sector. The standardised 1/4" hexagonal shank can be easily exchanged and is therefore perfect for screwing and drilling one after another.

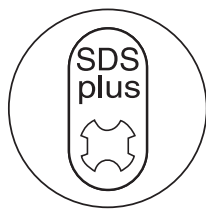

SDS-PLUS LOCKING

The SDS-plus shaft is directly fitting into all hammer drilling machines with SDS-plus and Hilti TE-C chuck.

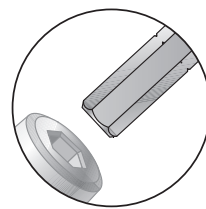

KEILBIT (C 6.3 MM)

This is a different kind of shaft of the KEILBIT with short hexagonal shank and short drill bit.

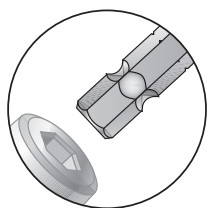

KEILBIT (E 6.3 MM)

Modern cordless screwdrivers are extremely powerful and can definitely be used for drilling. The KEILBIT has specially been invented for the fast and direct application in these machines. No change of machines is necessary anymore. For the various materials we offer different alternatives of the KEILBIT.

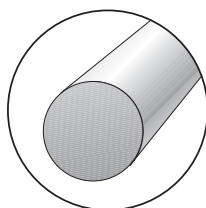

CYLINDRICAL SHAFT

Tools with round shaft are the top selling drilling tools. The round shaft is fitting into all three-jaw chucks and quick change chuck.

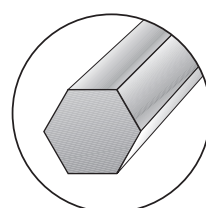

HEXAGONAL SCHAFT (10.0 MM)

The hexagonal shank offers a better transmission of rotation especially when working with big diameters and long drill bits.

180 | 280 WOOD TWIST DRILL BIT



DRIVE



EXECUTION

- Similar to DIN 7487
- Double chamfer from 5 mm \emptyset for Art. 180
- Milled and hardened
- Made of CV-alloyed silver steel
- CBN ground tip
- With carvers
- Burnished and ground surface

FOR USE IN



APPLICATION

- In all rotary and percussion drilling machines
- In machines for mechanical processing
- Only for rotary use

PACKAGING



[156]

[167]

Comments

- Other dimensions on request

D \emptyset mm	L2 mm	L1 mm	d \emptyset mm		EAN 4016707...	 12345
3,0	33	61	3,0	20	020018	180 000 030
4,0	43	75	4,0	20	020025	180 000 040
5,0	52	86	5,0	20	020032	180 000 050
6,0	57	93	6,0	20	020049	180 000 060
6,0	190	250	6,0	1	029011	280 060 250
7,0	69	109	7,0	20	020056	180 000 070
8,0	75	117	8,0	20	020063	180 000 080
8,0	190	250	8,0	1	029028	280 080 250
9,0	80	120	9,0	20	020070	180 000 090
10,0	87	120	10,0	20	020087	180 000 100
10,0	190	250	10,0	1	029035	280 100 250
11,0	89	142	8,0	10	020094	180 000 110
12,0	96	151	8,0	10	020100	180 000 120
12,0	190	250	10,0	1	029042	280 120 250
13,0	96	151	8,0	10	020117	180 000 130
14,0	96	151	10,0	10	020124	180 000 140
14,0	190	250	10,0	1	029059	280 140 250
15,0	100	160	10,0	10	020131	180 000 150
16,0	100	160	10,0	10	020148	180 000 160
16,0	190	250	10,0	1	029066	280 160 250
18,0	130	180	10,0	5	020155	180 000 180
18,0	190	250	10,0	1	029073	280 180 250
20,0	140	200	10,0	5	020162	180 000 200
20,0	190	250	10,0	1	029080	280 200 250
22,0	140	205	13,0	5	020179	180 000 220
24,0	140	215	13,0	5	020186	180 000 240
26,0	145	215	13,0	5	020193	180 000 260
28,0	145	220	13,0	4	020209	180 000 280
30,0	145	220	13,0	4	020216	180 000 300



WOOD TWIST DRILL BIT



PRODUCT INFORMATION:

- The double chamfer allows an exact lead in the drilling hole, also in low drilling depths and prevents chips of sticking between drill bit and hole walls
- These drill bits are particularly suitable for drilling plug holes and for drilling fibreboard, plywood, pine, beech, oak and similar hardwood and softwood.
- The precisely ground shoulder cutters provide completely round holes without any tearing.
- The special centring tip makes drilling of exact pilot holes possible.
- The Keil wood drill bits are ideal professional tools for the expert.
- To be used only in rotary drilling machines (hammer action, if any, must be switched off).
- The centring tip makes it possible to dispense with marking or scoring when this drill bit is used.
- Bit to be tensioned firmly and centred in chuck.
- Always place drill at right angle and then switch on start (slowly) with a low speed. Then continue drilling with the speed stated or recommended.
- Drilling always with constant pressure do not use a coolant.
- Lift out regularly, at least every 30 mm, and remove spoil from the flute. If this is not done and the flutes fill up, the bit will jam in the hole become hot and stop.
- The work piece should always be clamped tightly. Never let the centring tip impact on a hard underground (metal/stone) or drill into it.
- Blunt drill bits result in imprecise holes. Only sharp drill bits achieve optimum drilling results.
- Observe the safety regulations for all drilling work.

Recommended speed for Keil
wood twist drill bits 180

D Ø mm	 /min	 /min
3,0	1800	2600
4,0	1650	2500
5,0	1450	2200
6,0	1300	2000
7,0	1250	1900
8,0	1200	1800
9,0	1100	1700
10,0	1050	1600
11,0	1000	1500
12,0	900	1400
13,0	850	1300
14,0	800	1200
16,0	650	1000
18,0	500	800
20,0	400	600
22,0	400	600
24,0	350	500
26,0	300	450
28,0	250	400
30,0	200	300

186 HSS WOOD TWIST DRILL BIT



DRIVE



D Ø mm	L2 mm	L1 mm	d Ø mm	Icons	EAN 4016707	12345
4,0	43	75	4,0	20	027017	186 000 040
5,0	52	86	5,0	20	027024	186 000 050
6,0	57	93	6,0	20	027031	186 000 060
7,0	69	109	7,0	20	027048	186 000 070
8,0	75	117	8,0	20	027055	186 000 080
10,0	87	133	10,0	20	027079	186 000 100
12,0	96	151	8,0	10	027093	186 000 120

EXECUTION

- High-performance high-speed steel
- Milled flute
- 2 guiding phases bevels for better drill hole guidance
- Large groove for optimal chip flow
- Self cutting centre tip

FOR USE IN



- Especially suitable for furniture making
- Recommended speed of 1400 to 3500 rpm, depending on material and hole diameter

HSS WOOD TWIST DRILL BIT

The two self guiding chamfers allow splinter-proof entry and exit drillings. In contrary to the present type of drill bits no underlay is necessary anymore due to the new tip geometry.



APPLICATION

- In all rotary and percussion drilling machines as well as CNC machines
- In machines for mechanical processing
- Only for rotary use
- Exact, accurately centered and splinter free drilling in coated panel materials, chipboards, MDF-fiber boards as well as plastic and all kinds of soft and hard woods.

PACKAGING



Comments

- Other dimensions on request

187 WOOD TWIST DRILL BIT KEILBIT



DRIVE



EXECUTION

- Profile-ground
- Made of CV-alloyed silver steel
- Ground carbide tip
- With carvers
- Short, cylindrical
- 1/4" bit drive DIN 3126 - C 6.3

FOR USE IN



APPLICATION

- In all rotary and percussion drilling machines
- In machines for mechanical processing
- Only for rotary use
- In all drilling machines, cordless screw drivers and bit holders with 1/4" drill shank
- SDS-plus locating shank for Bits and KEILBIT [37]
- Quick bit holder for bits and KEILBIT [72]

PACKAGING



D ø mm	L1 mm	SW mm		EAN 4016707...	12345
3,0	40	6,35	20	028014	187 000 030
4,0	40	6,35	20	028021	187 000 040
5,0	50	6,35	20	028038	187 000 050
6,0	60	6,35	20	028045	187 000 060
8,0	70	6,35	20	028052	187 000 080
10,0	80	6,35	20	028069	187 000 100

WOOD TWIST DRILL BIT KEILBIT

- Modern cordless screw drivers are extremely efficient and can also be used for drilling without any problems. The KEILBIT was particularly developed for quick direct application in these machines.
- Machine changing is not necessary anymore.
- For drilling other materials we offer various types of KEILBIT.

181 AUGER BIT LEWIS SHAPE



DRIVE



EXECUTION

- Wood drill bit with threaded tip
- Carver and hexagonal shank
- With milled and ground spiral

FOR USE IN



APPLICATION

- In all rotary and percussion drilling machines
- In machines for mechanical processing
- Only for rotary use
- Precise and splinter-free drilling with point accuracy in veneered boards and all natural soft wood and hardwood

PACKAGING



D Ø mm	D Ø "	L2 mm	L1 mm	SW mm	d Ø mm	1	EAN 4016707...	12345
6,0	15/64	150	235		6,0	1	031403	181 060 250
8,0	5/16	150	235	7,00		1	031410	181 080 250
8,0	5/16	380	460	7,00		1	031151	181 080 450
10,0	3/8	150	235	9,00		1	031427	181 100 250
10,0	3/8	380	460	9,00		1	031168	181 100 450
10,0	3/8	530	600	9,00		1	031281	181 100 600
12,0	15/32	150	235	11,00		1	031434	181 120 250
12,0	15/32	380	460	11,00		1	031175	181 120 450
12,0	15/32	530	600	11,00		1	031298	181 120 600
14,0	9/16	150	235	12,00		1	031441	181 140 250
14,0	9/16	380	460	12,00		1	031182	181 140 450
14,0	9/16	530	600	12,00		1	031304	181 140 600
16,0	5/8	150	235	12,00		1	031458	181 160 250
16,0	5/8	380	460	12,00		1	031199	181 160 450
16,0	5/8	530	600	12,00		1	031311	181 160 600
18,0	11/16	150	235	12,00		1	031465	181 180 250
18,0	11/16	380	460	12,00		1	031205	181 180 450
18,0	11/16	530	600	12,00		1	031328	181 180 600
20,0	3/4	150	235	12,00		1	031472	181 200 250
20,0	3/4	380	460	12,00		1	031212	181 200 450
20,0	3/4	530	600	12,00		1	031335	181 200 600
22,0	7/8	150	235	12,00		1	031489	181 220 250
22,0	7/8	380	460	12,00		1	031229	181 220 450
22,0	7/8	530	600	12,00		1	031342	181 220 600
24,0	15/16	150	235	12,00		1	031496	181 240 250
24,0	15/16	380	460	12,00		1	031236	181 240 450
24,0	15/16	530	600	12,00		1	031359	181 240 600
26,0	11/32	150	235	12,00		1	031502	181 260 250
26,0	11/32	380	460	12,00		1	031243	181 260 450
28,0	11/8	150	235	12,00		1	031519	181 280 250
28,0	11/8	380	460	12,00		1	031250	181 280 450
30,0	13/16	150	235	12,00		1	031526	181 300 250
30,0	13/16	380	460	12,00		1	031267	181 300 450
32,0	11/4	150	235	12,00		1	031533	181 320 250
32,0	11/4	380	460	12,00		1	031274	181 320 450

182 AUGER DRILL BITS LEWIS SHAPE WITH SDS-PLUS SHAFT

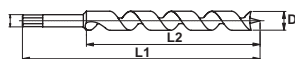

DRIVE

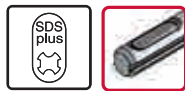

D Ø mm	D Ø "	L2 mm	L1 mm		EAN 4016707...	 12345
8,0	5/16	100	200	1	918810	182 080 200
10,0	3/8	160	235	1	918827	182 100 235
12,0	15/32	160	235	1	918834	182 120 235
16,0	5/8	160	235	1	918841	182 160 235
20,0	3/4	160	235	1	918858	182 200 235
22,0	7/8	160	235	1	918865	182 220 235
25,0	1	160	235	1	918872	182 250 235

EXECUTION

- Long service life thanks to special alloying
- Wear-resistant CV steel guarantees high strength and resistance to breakage
- Reduced SDS-plus shaft with open helix runout

FOR USE IN



APPLICATION

- Directly suitable for all hammer drill bits with SDS-plus and HILTI TE-C shank
- Only for rotating use
- Exact, precise and splinter-free drilling in coated board materials, chipboard, MDF boards as well as plastics and all kinds of soft and hardwoods.

PACKAGING



183 MACHINE FORSTNER DRILL BITS, TOOTHED



DRIVE



EXECUTION

- Forged from special steel
- Machine-ground to round shape
- According to DIN 7483
- Toothed execution from D=25mm

FOR USE IN



APPLICATION

- In all rotary and percussion drilling machines
- In machines for mechanical processing
- Only for rotary use
- Precise and splinter-free drilling with point accuracy in veneered boards and natural wood

PACKAGING



≥ 45 mm [167]

D ø mm	L1 mm	d ø mm		EAN 4016707...	12345
15,0	90	8,0	1	033223	183 000 150
18,0	90	8,0	1	033230	183 000 180
20,0	90	8,0	1	033247	183 000 200
22,0	90	8,0	1	033254	183 000 220
24,0	90	8,0	1	033261	183 000 240
25,0	90	8,0	1	033278	183 000 250
26,0	90	8,0	1	033285	183 000 260
28,0	90	8,0	1	033292	183 000 280
30,0	90	8,0	1	033308	183 000 300
35,0	90	10,0	1	033315	183 000 350
40,0	90	10,0	1	033322	183 000 400
45,0	90	10,0	1	033339	183 000 450

MACHINE FORSTNER DRILL BITS, TOOTHED

- Lower contact pressure
- Better and faster drilling progress
- Significantly longer life
- Less current consumption



185 FLAT BIT KEILBIT

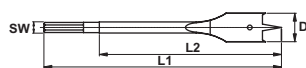

DRIVE



EXECUTION

- Tip and cutting edges profile ground
- Right-hand cutting
- Hardened tool steel
- 1/4" bit drive DIN 3126 - E 6.3

FOR USE IN



- For drilling in soft wood, beams and chip board

D Ø mm	L2 mm	L1 mm	SW mm		EAN 4016707...	
6,0	100	152	6,35	1	025013	185 060 150
8,0	100	152	6,35	1	025020	185 080 150
10,0	100	152	6,35	1	025037	185 100 150
12,0	100	152	6,35	1	025044	185 120 150
13,0	100	152	6,35	1	025051	185 130 150
14,0	100	152	6,35	1	025068	185 140 150
16,0	100	152	6,35	1	025075	185 160 150
18,0	100	152	6,35	1	025082	185 180 150
20,0	100	152	6,35	1	025099	185 200 150
22,0	100	152	6,35	1	025105	185 220 160
24,0	100	152	6,35	1	025112	185 240 160
25,0	100	152	6,35	1	025129	185 250 160
28,0	100	152	6,35	1	025136	185 280 160
30,0	100	152	6,35	1	025143	185 300 160
32,0	100	152	6,35	1	025150	185 320 160
35,0	100	152	6,35	1	025167	185 350 160
38,0	100	152	6,35	1	025174	185 380 160
40,0	100	152	6,35	1	025181	185 400 160

APPLICATION

- In all rotary and percussion drilling machines
- In machines for mechanical processing
- Only for rotary use
- In all drilling machines, cordless screw drivers and bit holders with 1/4" drill shank
- SDS-plus locating shank for Bits and KEILBIT [37]
- Quick bit holder for bits and KEILBIT [72]

PACKAGING

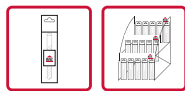



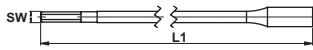

[168]

185 EXTENSION FOR FLAT BIT KEILBIT



DRIVE



L1  mm	SW  mm	 1	EAN  4016707...	 12345
300	6,35	1	025198	185 000 001

EXECUTION

- 1/4" bit drive DIN 3126 - E 6.3

FOR USE IN

- Can be used for through-holes from 16 mm drill bit diameter

APPLICATION

- In all rotary and percussion drilling machines
- In machines for mechanical processing
- In all drilling machines, cordless screw drivers and bit holders with 1/4" drill shank

PACKAGING



350 DRILL BIT FOR TIMBERING, ROUND SHANK

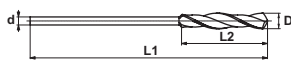

DRIVE



EXECUTION

- Made of wear resistant CV steel
- Long tool life due to special alloying
- Offset shank with open spiral outfall prevents from drill bit getting jammed
- Optimal true running accuracy as well as chip removal also in deep holes

FOR USE IN



APPLICATION

- In all rotary and percussion drilling machines
- To break through outer and inner covering boards in one operation
- Only for rotary use
- Also with concrete leftovers

PACKAGING

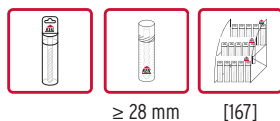

≥ 28 mm

[167]

D Ø mm	D Ø "	L2 mm	L1 mm	d Ø mm		EAN 4016707...	 12345
6,0	1/4	100	400	6,0	1	030130	350 060 400
6,0	1/4	100	600	6,0	1	030000	350 060 600
8,0	5/16	100	400	8,0	1	030017	350 080 400
8,0	5/16	100	600	8,0	1	030208	350 080 600
8,0	5/16	100	800	8,0	1	030710	350 080 800
10,0	3/8	100	400	8,0	1	030024	350 100 400
10,0	3/8	100	600	8,0	1	030215	350 100 600
10,0	3/8	100	800	8,0	1	030727	350 100 800
12,0	15/32	100	400	10,0	1	030031	350 120 400
12,0	15/32	100	600	10,0	1	030222	350 120 600
12,0	15/32	100	800	10,0	1	030734	350 120 800
14,0	9/16	100	400	10,0	1	030048	350 140 400
14,0	9/16	100	600	10,0	1	030239	350 140 600
14,0	9/16	100	800	10,0	1	030741	350 140 800
16,0	5/8	100	400	10,0	1	030055	350 160 400
16,0	5/8	100	600	10,0	1	030246	350 160 600
16,0	5/8	100	800	10,0	1	030758	350 160 800
18,0	11/16	100	400	13,0	1	030062	350 180 400
18,0	11/16	100	600	13,0	1	030253	350 180 600
18,0	11/16	100	800	13,0	1	030765	350 180 800
20,0	3/4	100	400	13,0	1	030079	350 200 400
20,0	3/4	100	600	13,0	1	030260	350 200 600
20,0	3/4	100	800	13,0	1	030772	350 200 800
22,0	7/8	100	400	13,0	1	030086	350 220 400
22,0	7/8	100	600	13,0	1	030277	350 220 600
22,0	7/8	100	800	13,0	1	030789	350 220 800
24,0	15/16	100	400	13,0	1	030093	350 240 400
24,0	15/16	100	600	13,0	1	030284	350 240 600
26,0	1 1/32	100	400	13,0	1	030109	350 260 400

Comments

- Largest clamping shank (d) 13 mm Ø
- Other dimensions on request

355 SDS-PLUS DRILL BIT FOR TIMBERING



DRIVE



EXECUTION

- Made of wear resistant CV steel
- Long tool life due to special alloying
- Offset shank with open spiral outfall prevents from drill bit getting jammed
- Optimal true running accuracy as well as chip removal also in deep holes

FOR USE IN



APPLICATION

- Fits directly into all hammer drilling machines with SDS-plus and HILTI TE-C drive
- Only for rotary use
- To break through outer and inner covering boards in one operation
- Also with concrete leftovers
- Adapters for SDS-plus [36]

PACKAGING



Comments

- Other dimensions on request

D Ø mm	D Ø "	L2 mm	L1 mm	d Ø mm		EAN 4016707...	
10,0	3/8	100	400	10,0	1	030406	355 100 400
10,0	3/8	100	600	10,0	1	030604	355 100 600
12,0	15/32	100	400	10,0	1	030413	355 120 400
12,0	15/32	100	600	10,0	1	030611	355 120 600
12,0	15/32	100	800	10,0	1	030963	355 120 800
14,0	9/16	100	400	10,0	1	030420	355 140 400
14,0	9/16	100	600	10,0	1	030628	355 140 600
14,0	9/16	100	800	10,0	1	030970	355 140 800
16,0	5/8	100	400	10,0	1	030437	355 160 400
16,0	5/8	100	600	10,0	1	030635	355 160 600
16,0	5/8	100	800	10,0	1	030987	355 160 800
18,0	11/16	100	400	10,0	1	030444	355 180 400
18,0	11/16	100	600	10,0	1	030642	355 180 600
18,0	11/16	100	800	10,0	1	030994	355 180 800
20,0	3/4	100	400	10,0	1	030451	355 200 400
20,0	3/4	100	600	10,0	1	030659	355 200 600
20,0	3/4	100	800	10,0	1	031007	355 200 800
22,0	7/8	100	400	10,0	1	030468	355 220 400
22,0	7/8	100	600	10,0	1	030666	355 220 600
22,0	7/8	100	800	10,0	1	031014	355 220 800
24,0	15/16	100	400	10,0	1	030475	355 240 400
24,0	15/16	100	600	10,0	1	030673	355 240 600

SAWS



100 Carpentry saw	133
100 Fine cut saw	133
100 NEO fine cut saw	134
100 Fine cut saw with double edged blade	134
100 MICRO pull saw with metal blade	135
100 Drywall saw	135
100 Pruning saw	136
100 Large pruning saw	136

SAWS

Shark saw, the precision pull saw. With only 20 % of your physical power you cut 5 times more than with classical saws.

HAIFISCHSÄGE Die Präzisions-Zugsäge

SHARKSAW

The shark saw has three cutting edges which allows cross and rip cutting. The electronic pulse hardening provides up to 3 times longer tool life and the teeth are individually ground by diamonds. In spite of the thin blade it is easy and safe to start sawing without bending or unevenness.



SAW BLADE

The thinner the saw blade the faster the cut. This saw blade is made of high quality carbon steel. The thin saw blade allows thin, clean and flush cuts.



CARPENTRY SAW

The carpentry saw is available in two different sizes. The 14 teeth/inch saw is suitable for general carpentry in plywood, treated wood, plastics and hard wood. The 10 teeth/inch saw is better suitable for beams, branches, framing timber, standing timber etc.



FINE CUT SAW

The fine cut saw perfectly works in plywood, thin PVC, hard wood etc. With this saw fine and thin cuts can be made. Therefore the saw is suitable for model making.



PRUNING SAW

The garden saw is suitable for timber, branches, construction timber and natural wood, ABS-and PVC pipes. The saw for gardening.



DRYWALL SAW

The drywall saw is well suitable for interior works. It is for plasterboards, gypsum fiber boards, plywood, tree roots etc.

EASY SAWING, EASY GOING

- Clamp the work piece or provide a firm support with stop in the direction of the pull.
- Check the work piece for obstructions (screws, nails, etc.). These may damage the saw.
- Maintain a cutting angle of less than 10°.
- The weight of the saw executes the cut on its own.
- Slightly increase the pressure on the saw once a small groove has been cut.
- Always pull the saw briskly and without great application of force.
- Use the full length of the saw blade by pulling the saw uniformly through.
- Always fit the protector over the teeth when finished. This ensures a long life of the shark saw.
- Store the saw safely away from children.



PRECISION - THE PULL CUT

- Makes possible a thin saw blade
- Easy and safe start
- No bending, no unevenness
- Precise and controlled cut

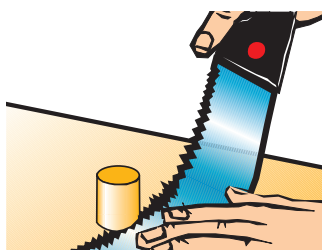

APPEED - THIN SAW BLADE

- The thinner the blade, the faster the cut
- Made of high-quality carbon steel
- Thin and clean cuts
- Flush cut due to the flexible blade

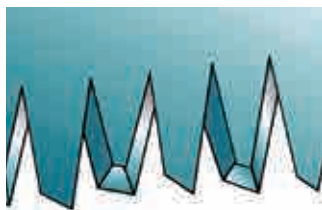

HANDLING - TEETH

- The triple edge teeth make possible cross and rip cutting
- Electronic pulse hardening provides up to 3 times longer tool life
- The teeth are ground individually using diamond



LITTLE FORCE REQUIRED

- Hold the handle lightly
- The pulling cut does not require great force or strength
- Guide the saw and let it make the cut itself using its own weight

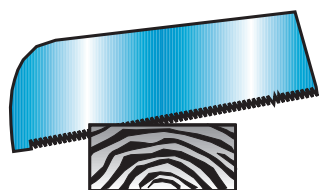

CUTTING ANGLE LESS THAN 10°

- It is important that the cutting angle is less than 10°

100 CARPENTRY SAW

EXECUTION

- Replaceable saw blade
- Two-components safety handle

FOR USE IN



- 14 teeth/inch suitable for general carpentry, plywood, treated material, PVC and ABS, hard wood, etc.
- 10 teeth/inch suitable for wooden beams, framing timber, treated material, standing timber, branches, etc.

PACKAGING



[168]

Comments

- Each 300 mm blades and 380 mm blades fit in the same handle



mm	Teeth	Pieces	EAN	Accessories
300	14	4	530326	100 112 312
380	10	4	530340	100 112 415

REPLACEMENT SAW BLADE FOR CARPENTRY SAW



mm	Teeth	Pieces	EAN	Accessories
300	14	4	530333	100 022 312
380	10	4	530357	100 022 415

100 FINE CUT SAW

EXECUTION

- Replaceable saw blade
- Two-components safety handle

FOR USE IN



- For fine cuts, plywood, thin PVC, hard wood, etc.

PACKAGING



[168]

Comments

- Well suitable for model making because it allows very fine and thin cuts



mm	Teeth	Pieces	EAN	Accessories
270	19	4	530043	100 112 410

REPLACEMENT SAW BLADE FOR FINE CUT SAW



mm	Teeth	Pieces	EAN	Accessories
270	19	4	530050	100 022 410

100 NEO FINE CUT SAW

EXECUTION

- Replaceable saw blade
- Traditionally long bast wrapped handle

FOR USE IN

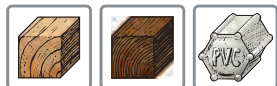

- 15 teeth/inch suitable for general fine cuts, plywood, furniture making, treated wood, etc.
- 12 teeth/inch suitable for general carpentry, plywood, treated material, PVC and ABS, hard wood, etc.

Comments

- Each 265 mm blades and 300 mm blades fit in the same handle



mm	Teeth	Pkg	EAN	Code
265	15	4	530364	100 110 265
300	12	4	530388	100 110 300

REPLACEMENT SAW BLADE FOR NEO FINE CUT SAW



mm	Teeth	Pkg	EAN	Code
265	15	4	530371	100 020 265
300	12	4	530395	100 020 300

100 FINE CUT SAW WITH DOUBLE EDGED BLADE

EXECUTION

- Replaceable saw blade
- Long handle

FOR USE IN

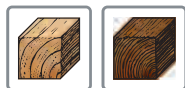

- For flush cuts, stair cases, plywood and general fine cuts

PACKAGING



[168]



mm	Teeth	Pkg	EAN	Code
240	9-17	4	530081	100 112 440

REPLACEMENT SAW BLADE WITH DOUBLE EDGE



mm	Teeth	Pkg	EAN	Code
240	9-17	4	530098	100 022 440

100 MICRO PULL SAW WITH METAL BLADE

EXECUTION

- Replaceable saw blade
- Two-components handle

FOR USE IN

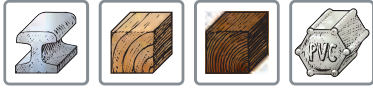

- Fine cuts in softwood and hard wood
- Suitable for handicrafts and fine cut
- Replacement saw blade metal for cutting thin metal panels, aluminium and mild steel

PACKAGING



[168]



 mm	 3"		 EAN 4016707...	 12345
160	29	4	530296	100 100 554

EREPLACEMENT SAW BLADE FOR MICRO PULL SAW



 mm	 3"		 EAN 4016707...		 12345
160	19	4	530302	für Holz	100 010 554
160	29	4	530319	für Metall	100 010 555

100 DRYWALL SAW

EXECUTION

- Ergonomically designed handle
- Extremely stiff and fixed blade
- Thinned tip

FOR USE IN







- For plasterboard, fibrous plasterboard, gypsum, plywood, tree roots, etc.

Comments

- Well suitable for interior works



 mm	 3"		 EAN 4016707...	 12345
155	8	4	530401	100 112 206

100 PRUNING SAW

EXECUTION

- Saw with folding blade
- Partially replaceable saw blade



FOR USE IN



- Standing timber, branches, construction timber natural wood, ABS- and plastic tubes.

mm	X ³	Box	EAN 4016707...	12345
180	7	6	530135	100 105 418
210	9	4	530104	100 105 427

PACKAGING



[168]

Comments

- Well suitable for gardening
- ECO model with a working length of 180 mm

REPLACEMENT SAW BLADE FOR PRUNING SAW



mm	X ³	Box	EAN 4016707...	12345
180	7	1	530128	100 015 418
210	9	1	530111	100 015 427

100 LARGE PRUNING SAW

EXECUTION

- With sheath and belt holder



FOR USE IN



- Standing timber, branches, construction timber natural wood, ABS- and plastic tubes.

mm	X ³	Box	EAN 4016707...	12345
240	7	10	530142	100 105 424

PACKAGING



[168]

Comments

- Well suitable for gardening

REPLACEMENT SAW BLADE FOR PRUNING SAW



mm	X ³	Box	EAN 4016707...	12345
240	7	1	530159	100 015 424

ASSORTMENTS



- Hammer drill bit
- Percussion drill bit
- Metal drill bit
- Wood drill bit

- 139-142
- 143-144
- 145-153
- 154

HAMMER DRILL BITS

CHISELS

STONE AND
SPECIAL DRILL BITS

METAL DRILL BITS

WOOD DRILL BITS

SAWS

ASSORTMENTS

MODULES

EVERYTHING AT YOUR FINGERTIPS

No matter if RoseBox, case or a sales display: Keil always offers a possibility to store your tools and to protect it from damage.



ROSEBOX

The RoseBox is a tool cassette made of ABS plastic. It can be stacked and it is resistant against impact and breakage. In contrary to the classic metal cassettes the RoseBox does not rust and has no sharp edges. With its modern design it is a high quality storing box for professional tools.



INDUSTRIAL PACKS/ RECTANGLEPACK

In contrary to the craftsman the industrial user continuously needs the same diameter. For this purpose we offer HSS drill bits and hammer drill bits with SDS-plus drive in 10 pcs./respectively 5 pcs. of the same diameter in plastic pack.



CASE

We offer high quality plastic and metal cases equipped with premium tools for various fields of applications, e.g. HSS bi-metal hole saws, HSS drill bits or drill bits for ceramics.



MULTIPACK

MultiPacks can be found for many types of drill bits out of our assortment. These packs are impact-proofed and space saving. Within the tool presentation in the shops drilling tools are noticeable due to its transparent material.





SALES DISPLAY





The Keil sales displays provide presentation and storage of the tools with minimum space.

HAMMER DRILL BITS

251 MultiPack SDS-plus TURBOHEAD Xpro RS









	 D Ø mm	 L2 mm	 L1 mm
1	5,0	50	110
1	6,0	50	110
1	6,0	100	160
1	8,0	100	160
1	10,0	100	160

			
5	10	904745	251 350 510

251 MultiPack SDS-plus TURBOHEAD Xpro RS









	 D Ø mm	 L2 mm	 L1 mm
1	5,0	100	160
2	6,0	100	160
2	8,0	100	160
1	10,0	100	160
1	12,0	100	160

			
7	10	904752	251 370 512

251 RoseBox SDS-plus TURBOHEAD Xpro RS











	 D Ø mm	 L2 mm	 L1 mm
1	5,0	50	110
1	6,0	50	110
1	6,0	100	160
1	8,0	50	110
1	8,0	100	160
1	10,0	100	160
1	12,0	100	160

			
7	1	902505	251 500 512

251 RectanglePack SDS-plus TURBOHEAD Xpro RS









 D Ø mm	 D "	 L2 mm	 L1 mm				
5,0	3/16	50	110	10	1	902703	251 950 110
5,0	3/16	100	160	10	1	902710	251 950 160
6,0	15/64	50	110	10	1	902727	251 960 110
6,0	15/64	100	160	10	1	902734	251 960 160
6,0	15/64	150	210	10	1	902741	251 960 210
6,0	15/64	200	260	10	1	902758	251 960 260
8,0	5/16	50	110	10	1	902765	251 980 110
8,0	5/16	100	160	10	1	902772	251 980 160
8,0	5/16	150	210	10	1	902789	251 980 210
8,0	5/16	200	260	10	1	902796	251 980 260
10,0	3/8	100	160	10	1	902611	251 900 160
10,0	3/8	150	210	10	1	902628	251 900 210
10,0	3/8	200	260	10	1	902635	251 900 260
12,0	15/32	100	160	10	1	902642	251 920 160
12,0	15/32	150	210	10	1	902659	251 920 210
12,0	15/32	200	260	10	1	902666	251 920 260
14,0	17/32	100	160	5	1	902673	251 940 160
14,0	17/32	150	210	5	1	902680	251 940 210
14,0	17/32	200	260	5	1	902697	251 940 260

HAMMER DRILL BITS

267 RoseBox
SDS-plus POWER-4CE









			
	D Ø mm	L2 mm	L1 mm
1	5,0	50	110
1	6,0	50	110
1	8,0	50	110
1	6,0	100	160
1	8,0	100	160
1	10,0	100	160
1	12,0	100	160

			
7	1	EAN 4016707...	T12345
		924736	267 500 512

267 MultiPack
SDS-plus POWER-4CE









			
	D Ø mm	L2 mm	L1 mm
1	5,0	50	110
1	6,0	50	110
1	6,0	100	160
1	8,0	100	160
1	10,0	100	160

			
5	10	EAN 4016707...	T12345
		924712	267 350 510

267 MultiPack
SDS-plus POWER-4CE











			
	D Ø mm	L2 mm	L1 mm
1	5,0	50	110
1	6,0	50	110
1	6,0	100	160
1	8,0	50	110
1	8,0	100	160
1	10,0	100	160
1	12,0	100	160

			
7	10	EAN 4016707...	T12345
		924729	267 370 512

267 RectanglePack
SDS-plus POWER-4CE









							
D Ø mm	D "	L2 mm	L1 mm			EAN 4016707...	T12345
5,0	3/16	50	110	10	1	924514	267 950 110
5,0	3/16	100	160	10	1	924521	267 950 160
6,0	15/64	50	110	10	1	924538	267 960 110
6,0	15/64	100	160	10	1	924545	267 960 160
6,0	15/64	150	210	10	1	924552	267 960 210
6,0	15/64	200	260	10	1	924569	267 960 260
8,0	5/16	50	110	10	1	924576	267 980 110
8,0	5/16	100	160	10	1	924583	267 980 160
8,0	5/16	150	210	10	1	924590	267 980 210
8,0	5/16	200	260	10	1	924606	267 980 260
10,0	3/8	50	110	10	1	924613	267 900 110
10,0	3/8	100	160	10	1	924620	267 900 160
10,0	3/8	150	210	10	1	924637	267 900 210
10,0	3/8	200	260	10	1	924644	267 900 260
12,0	15/32	100	160	10	1	924651	267 920 160
12,0	15/32	150	210	10	1	924668	267 920 210
12,0	15/32	200	260	10	1	924675	267 920 260
14,0	17/32	100	160	5	1	924682	267 940 160
14,0	17/32	140	200	5	1	924699	267 940 200
14,0	17/32	190	250	5	1	924705	267 940 250

HAMMER DRILL BITS

253 MultiPack SDS-plus MS5 TURBOKEIL









	 D Ø mm	 L2 mm	 L1 mm
1	5,0	50	110
1	6,0	50	110
1	6,0	100	160
1	8,0	100	160
1	10,0	100	160

			
5	10	904790	253 350 510

253 MultiPack SDS-plus MS5 TURBOKEIL









	 D Ø mm	 L2 mm	 L1 mm
1	5,0	100	160
2	6,0	100	160
2	8,0	100	160
1	10,0	100	160
1	12,0	100	160

			
7	10	904806	253 370 512

253 RoseBox SDS-plus MS5 TURBOKEIL











	 D Ø mm	 L2 mm	 L1 mm
1	5,0	50	110
1	6,0	50	110
1	6,0	100	160
1	8,0	50	110
1	8,0	100	160
1	10,0	100	160
1	12,0	100	160

			
7	1	322396	253 500 512

253 | 502 RoseBox SDS-plus MS5 TURBOKEIL Chisel SET











	 D Ø mm	 L2 mm	 L1 mm	 B mm
2	6,0	100	160	
1	8,0	100	160	
1	10,0	100	160	
1	12,0	100	160	
Point chisel	1		140	
Flat chisel	1		140	20

			
7	1	329944	253 273 274

253 RectanglePack SDS-plus MS5 TURBOKEIL



 D Ø mm	 D Ø "	 L2 mm	 L1 mm				
5,0	3/16	50	110	10	1	322211	253 950 115
5,0	3/16	100	160	10	1	322228	253 950 165
6,0	15/64	50	110	10	1	322235	253 960 115
6,0	15/64	100	160	10	1	322242	253 960 165
6,0	15/64	150	210	10	1	323539	253 960 210
6,0	15/64	200	260	10	1	323461	253 960 260
8,0	5/16	50	110	10	1	322259	253 980 115
8,0	5/16	100	160	10	1	322266	253 980 160
8,0	5/16	150	210	10	1	322273	253 980 215
8,0	5/16	200	260	10	1	323478	253 980 260
10,0	3/8	50	110	10	1	322655	253 900 110
10,0	3/8	100	160	10	1	322280	253 900 165
10,0	3/8	150	210	10	1	322297	253 900 210
10,0	3/8	200	260	10	1	323485	253 900 260
12,0	15/32	100	160	10	1	322303	253 920 165
12,0	15/32	150	210	10	1	322310	253 920 215
12,0	15/32	200	260	10	1	323492	253 920 265
14,0	17/32	100	160	5	1	323508	253 940 165
14,0	17/32	150	210	5	1	323515	253 940 215
14,0	17/32	200	260	5	1	323522	253 940 265







HAMMER DRILL BITS
CHISELS
STONE AND SPECIAL DRILL BITS
METAL DRILL BITS
WOOD DRILL BITS
SAWS
ASSORTMENTS
MODULES

HAMMER DRILL BITS

256 MultiPack

SDS-plus hammer drill bit KEILRAPID









	 D Ø mm	 L2 mm	 L1 mm
1	5,0	50	110
1	6,0	50	110
1	6,0	100	160
1	8,0	100	160
1	10,0	100	160
		 EAN 4016707...	 T12345
5	10	920165	256 350 510

256 MultiPack

SDS-plus hammer drill bit KEILRAPID











	 D Ø mm	 L2 mm	 L1 mm
1	5,0	100	160
2	6,0	100	160
2	8,0	100	160
1	10,0	100	160
1	12,0	100	160
		 EAN 4016707...	 T12345
7	10	920158	256 370 512

256 RectanglePack

SDS-plus hammer drill bit KEILRAPID









 D Ø mm	 D "	 L2 mm	 L1 mm			 EAN 4016707...	 T12345
5,0	3/16	50	110	10	1	920172	256 950 110
5,0	3/16	100	160	10	1	920189	256 950 160
6,0	15/64	50	110	10	1	920196	256 960 110
6,0	15/64	100	160	10	1	920202	256 960 160
6,0	15/64	150	210	10	1	920219	256 960 210
6,0	15/64	200	260	10	1	920226	256 960 260
8,0	5/16	50	110	10	1	920233	256 980 110
8,0	5/16	100	160	10	1	920240	256 980 160
8,0	5/16	150	210	10	1	920257	256 980 210
8,0	5/16	200	260	10	1	920264	256 980 260
10,0	3/8	50	110	10	1	921131	256 900 110
10,0	3/8	100	160	10	1	920271	256 900 160
10,0	3/8	150	210	10	1	920288	256 900 210
10,0	3/8	200	260	10	1	920295	256 900 260
12,0	15/32	100	160	10	1	920301	256 920 160
12,0	15/32	150	210	10	1	920318	256 920 210
12,0	15/32	200	260	10	1	920325	256 920 260
14,0	17/32	100	160	5	1	920332	256 940 160
14,0	17/32	150	210	5	1	920349	256 940 210
14,0	17/32	200	250	5	1	920356	256 940 250

272 Keep case

SDS-plus TURBOCLEAN









 D Ø mm	 D "	 L2 mm	 L1 mm	 EAN 4016707...	 T12345
6,0	15/64	100	220	924408	272 060 220
8,0	5/16	100	220	924415	272 080 220
10,0	3/8	100	220	924422	272 100 220
0	0	0		924439	272 000 002
0	0	100	220	924446	272 610 220

STONE AND SPECIAL DRILL BITS







119 MultiPack Universal drill bit GOLDCRAFT



			
	Ø mm	mm	mm
1	4,0	40	75
1	5,0	50	85
1	6,0	60	100
1	8,0	80	120
1	10,0	80	120
			
5	10	904820	119 350 410

119 RosePack Universal drill bit GOLDCRAFT



			
	Ø mm	mm	mm
1	4,0	40	75
1	5,0	50	85
2	6,0	60	100
1	8,0	80	120
1	10,0	80	120
1	12,0	90	150
			
7	1	212628	119 501 412







786 Keep case Tile drill bit/KERAMIK diamond - dry drill



				
	Ø mm	mm	mm	
KERAMIK Diamond	1	6,0	67	
KERAMIK Diamond	1	8,0	80	
KERAMIK Diamond	1	10,0	80	
Spray bottle 100ml (empty)	1			
Vacuum guide small 4-13mm	1			
KERAMIK TSM	1	4,0	40	75
KERAMIK TSM	1	5,0	50	85
KERAMIK TSM	1	6,0	60	100
				
8	1	905834	786 151 098	







119 MultiPack Universal drill bit GOLDCRAFT



			
	Ø mm	mm	mm
1	4,0	40	75
1	5,0	50	85
2	6,0	60	100
1	8,0	80	120
1	10,0	80	120
1	12,0	90	150
			
7	10	904837	119 370 412







151 MultiPack Tile/brick drill bit KERAMIK with TSM carbide tip



			
	Ø mm	mm	mm
1	4,0	40	75
1	5,0	50	85
1	6,0	60	100
1	8,0	80	120
1	10,0	80	120
			
5	10	904868	151 350 410





168 MultiPack Hard stone drill bit HARDTEC



			
	Ø mm	mm	mm
1	4,0	40	75
1	5,0	50	85
1	6,0	60	100
1	8,0	75	120
1	10,0	75	120
			
5	10	916045	168 350 410

715 Cardboard box Universal hollow core



		
	Ø mm	mm
Universal hollow core	1	33,0
Universal hollow core	1	53,0
Universal hollow core	1	67,0
Universal hollow core	1	73,0
Locating plate	1	
Centre drill bits	1	9,0 140
		
6	1	250019 715 033 073

STONE AND SPECIAL DRILL BITS

HAMMER DRILL BITS

CHISELS

STONE AND SPECIAL DRILL BITS

METAL DRILL BITS

WOOD DRILL BITS

SAWS

ASSORTMENTS

MODULES

258 MultiPack
Concrete drill bit MS5 TURBOKEIL



	D ø mm	L2 mm	L1 mm
1	4,0	40	85
1	5,0	50	85
1	6,0	60	100
1	8,0	75	120
1	10,0	75	120

	Hand icon	Box icon	EAN 4016707...	12345 icon
5	10	904929	258 350 410	

154 MultiPack
Granite drill bit PRIMUS



	D ø mm	L2 mm	L1 mm
1	4,0	40	75
1	5,0	50	85
1	6,0	60	100
1	8,0	80	120
1	10,0	80	120

	Hand icon	Box icon	EAN 4016707...	12345 icon
5	10	904899	154 350 410	

154 MultiPack
Granite drill bit PRIMUS



	D ø mm	L2 mm	L1 mm
1	4,0	40	75
1	5,0	50	85
2	6,0	60	100
1	8,0	80	120
1	10,0	80	120
1	12,0	90	150

	Hand icon	Box icon	EAN 4016707...	12345 icon
7	10	904905	154 370 412	



154 RoseBox
Granite drill bit PRIMUS

	D ø mm	L2 mm	L1 mm
1	4,0	40	75
1	5,0	50	85
2	6,0	60	100
1	8,0	80	120
1	10,0	80	120
1	12,0	90	150

	Hand icon	Box icon	EAN 4016707...	12345 icon
7	1	192951	154 501 412	

150 MultiPack
Percussion drill bit KEILER



	D ø mm	L2 mm	L1 mm
1	4,0	40	75
1	5,0	50	85
1	6,0	60	100
1	8,0	80	120
1	10,0	80	120

	Hand icon	Box icon	EAN 4016707...	12345 icon
5	10	904851	150 350 410	



190 MultiPack
Masonry drill bit OPAL

	D ø mm	L2 mm	L1 mm
1	4,0	40	75
1	5,0	50	85
1	6,0	60	100
1	8,0	80	120
1	10,0	80	120

	Hand icon	Box icon	EAN 4016707...	12345 icon
5	10	904912	190 350 410	

166 MultiPack
Universal drill bit KEILBIT



	D ø mm	L2 mm	L1 mm
1	4,0	45	85
1	5,0	50	95
1	6,0	60	100
1	8,0	70	120
1	10,0	70	120

	Hand icon	Box icon	EAN 4016707...	12345 icon
5	10	220074	166 350 410	



238 MultiPack
Concrete drill bit MS5 TURBOHEAD Xpro

	D ø mm	L2 mm	L1 mm
1	5,0	50	85
1	6,0	60	100
1	6,0	60	100
1	8,0	75	120
1	10,0	75	120

	Hand icon	Box icon	EAN 4016707...	12345 icon
5	10	912795	238 350 510	

METAL DRILL BITS

307 MultiPack
HSS-E DIN 338 cobalt, ground,
split point



	D ∅ mm	L2 mm	L1 mm
1	4,0	43	75
1	5,0	52	86
1	6,0	57	93
1	8,0	75	117
1	10,0	87	133
5	10	904950	307 350 410

307 Cassette
HSS-E DIN 338 cobalt, ground,
split point



	D ∅ mm	L2 mm	L1 mm
1	1,5	18	40
1	2,0	24	49
1	2,5	30	57
1	3,0	33	61
1	3,2	36	65
1	3,5	39	70
1	4,0	43	75
1	4,5	47	80
1	4,8	52	86
1	5,0	52	86
1	5,5	57	93
1	6,0	57	93
1	6,5	63	101
13	10	062506	307 213 165

307 RoseBox
HSS-E DIN 338 cobalt, ground,
split point



	D ∅ mm	L2 mm	L1 mm
1	1,0	12	34
1	1,5	18	40
1	2,0	24	49
1	2,5	30	57
1	3,0	33	61
1	3,5	39	70
1	4,0	43	75
1	4,5	47	80
1	5,0	52	86
1	5,5	57	93
1	6,0	57	93
1	6,5	63	101
1	7,0	69	109
1	7,5	69	109
1	8,0	75	117
1	8,5	75	117
1	9,0	81	125
1	9,5	81	125
1	10,0	87	133
19	1	065507	307 501 110

307 Metal box
HSS-E DIN 338 cobalt, ground,
split point



	D ∅ mm	L2 mm	L1 mm
1	1,0	12	34
1	1,5	18	40
1	2,0	24	49
1	2,5	30	57
1	3,0	33	61
1	3,5	39	70
1	4,0	43	75
1	4,5	47	80
1	5,0	52	86
1	5,5	57	93
1	6,0	57	93
1	6,5	63	101
1	7,0	69	109
1	7,5	69	109
1	8,0	75	117
1	8,5	75	117
1	9,0	81	125
1	9,5	81	125
1	10,0	87	133
19	1	062513	307 500 110

HAMMER DRILL BITS

CHISELS

STONE AND
SPECIAL DRILL BITS

METAL DRILL BITS

WOOD DRILL BITS

SAWS

ASSORTMENTS





MODULES

METAL DRILL BITS

307 RoseBox

HSS-E DIN 338 cobalt, ground,
split point



				
	\emptyset mm	L2 mm	L1 mm	
1	1,0	12	34	
1	1,5	18	40	
1	2,0	24	49	
1	2,5	30	57	
1	3,0	33	61	
1	3,5	39	70	
1	4,0	43	75	
1	4,5	47	80	
1	5,0	52	86	
1	5,5	57	93	
1	6,0	57	93	
1	6,5	63	101	
1	7,0	69	109	
1	7,5	69	109	
1	8,0	75	117	
1	8,5	75	117	
1	9,0	81	125	
1	9,5	81	125	
1	10,0	87	133	
1	10,5	87	133	
1	11,0	94	142	
1	11,5	94	142	
1	12,0	101	151	
1	12,5	101	151	
1	13,0	101	151	



25



1



065514







307 501 113

307 Metal box

HSS-E DIN 338 cobalt, ground,
split point



				
	\emptyset mm	L2 mm	L1 mm	
1	1,0	12	34	
1	1,5	18	40	
1	2,0	24	49	
1	2,5	30	57	
1	3,0	33	61	
1	3,5	39	70	
1	4,0	43	75	
1	4,5	47	80	
1	5,0	52	86	
1	5,5	57	93	
1	6,0	57	93	
1	6,5	63	101	
1	7,0	69	109	
1	7,5	69	109	
1	8,0	75	117	
1	8,5	75	117	
1	9,0	81	125	
1	9,5	81	125	
1	10,0	87	133	
1	10,5	87	133	
1	11,0	94	142	
1	11,5	94	142	
1	12,0	101	151	
1	12,5	101	151	
1	13,0	101	151	



25



1



062520







307 500 113

307 Metal box

HSS-E DIN 338 cobalt, ground,
split point



				
	\emptyset mm	L2 mm	L1 mm	
10	1,0	12	34	
10	1,5	18	40	
10	2,0	24	49	
10	2,5	30	57	
10	3,0	33	61	
10	3,5	39	70	
10	4,0	43	75	
10	4,5	47	80	
10	5,0	52	86	
10	5,5	57	93	
10	6,0	57	93	
10	6,5	63	101	
10	7,0	69	109	
10	7,5	69	109	
10	8,0	75	117	
5	8,5	75	117	
5	9,0	81	125	
5	9,5	81	125	
5	10,0	87	133	



170



1



062537









307 800 170

METAL DRILL BITS

311 RoseBox
HSS TIN DIN 338 steel drill bit









	 D Ø mm	 L2 mm	 L1 mm
1	1,0	12	34
1	1,5	18	40
1	2,0	24	49
1	2,5	30	57
1	3,0	33	61
1	3,5	39	70
1	4,0	43	75
1	4,5	47	80
1	5,0	52	86
1	5,5	57	93
1	6,0	57	93
1	6,5	63	101
1	7,0	69	109
1	7,5	69	109
1	8,0	75	117
1	8,5	75	117
1	9,0	81	125
1	9,5	81	125
1	10,0	87	133

			
19	1	920653	311 501 110

311 RoseBox
HSS TIN DIN 338 steel drill bit



	 D Ø mm	 L2 mm	 L1 mm
1	1,0	12	34
1	1,5	18	40
1	2,0	24	49
1	2,5	30	57
1	3,0	33	61
1	3,5	39	70
1	4,0	43	75
1	4,5	47	80
1	5,0	52	86
1	5,5	57	93
1	6,0	57	93
1	6,5	63	101
1	7,0	69	109
1	7,5	69	109
1	8,0	75	117
1	8,5	75	117
1	9,0	81	125
1	9,5	81	125
1	10,0	87	133
1	10,5	87	133
1	11,0	94	142
1	11,5	94	142
1	12,0	101	151
1	12,5	101	151
1	13,0	101	151

			
25	1	920660	311 501 113

HAMMER DRILL BITS

CHISELS

STONE AND
SPECIAL DRILL BITS

METAL DRILL BITS

WOOD DRILL BITS

SAWS

ASSORTMENTS

MODULES

METAL DRILL BITS

HAMMER DRILL BITS

CHISELS

STONE AND SPECIAL DRILL BITS

METAL DRILL BITS

WOOD DRILL BITS







SAWS

ASSORTMENTS

MODULES









302 MultiPack
HSS DIN 338 ground, split point

	 D ø mm	 L2 mm	 L1 mm
1	4,0	43	75
1	5,0	52	86
1	6,0	57	93
1	8,0	75	117
1	10,0	87	133
 5	 10	 EAN 4016707... 904943	 T12345 302 350 410









302 Plastic cassette
HSS DIN 338 ground, split point

	 D ø mm	 L2 mm	 L1 mm
1	1,5	18	40
1	2,0	24	49
1	2,5	30	57
1	3,0	33	61
1	3,2	36	65
1	3,5	39	70
1	4,0	43	75
1	4,5	47	80
1	4,8	52	86
1	5,0	52	86
1	5,5	57	93
1	6,0	57	93
1	6,5	63	101
 13	 10	 EAN 4016707... 122200	 T12345 302 213 165







302 RoseBox
HSS DIN 338 ground, split point



	 D ø mm	 L2 mm	 L1 mm
1	1,0	12	34
1	1,5	18	40
1	2,0	24	49
1	2,5	30	57
1	3,0	33	61
1	3,5	39	70
1	4,0	43	75
1	4,5	47	80
1	5,0	52	86
1	5,5	57	93
1	6,0	57	93
1	6,5	63	101
1	7,0	69	109
1	7,5	69	109
1	8,0	75	117
1	8,5	75	117
1	9,0	81	125
1	9,5	81	125
1	10,0	87	133
 19	 1	 EAN 4016707... 122224	 T12345 302 501 110





302 Metal box
HSS DIN 338 ground, split point





	 D ø mm	 L2 mm	 L1 mm
1	1,0	12	34
1	1,5	18	40
1	2,0	24	49
1	2,5	30	57
1	3,0	33	61
1	3,5	39	70
1	4,0	43	75
1	4,5	47	80
1	5,0	52	86
1	5,5	57	93
1	6,0	57	93
1	6,5	63	101
1	7,0	69	109
1	7,5	69	109
1	8,0	75	117
1	8,5	75	117
1	9,0	81	125
1	9,5	81	125
1	10,0	87	133
 19	 1	 EAN 4016707... 120350	 T12345 302 500 110

METAL DRILL BITS

302 RoseBox HSS DIN 338 ground, split point









	 D ø mm	 L2 mm	 L1 mm
1	1,0	12	34
1	1,5	18	40
1	2,0	24	49
1	2,5	30	57
1	3,0	33	61
1	3,5	39	70
1	4,0	43	75
1	4,5	47	80
1	5,0	52	86
1	5,5	57	93
1	6,0	57	93
1	6,5	63	101
1	7,0	69	109
1	7,5	69	109
1	8,0	75	117
1	8,5	75	117
1	9,0	81	125
1	9,5	81	125
1	10,0	87	133
1	10,5	87	133
1	11,0	94	142
1	11,5	94	142
1	12,0	101	151
1	12,5	101	151
1	13,0	101	151

 25
  1
  4016707... 122231
  302 501 113

302 Metal box HSS DIN 338 ground, split point









	 D ø mm	 L2 mm	 L1 mm
1	1,0	12	34
1	1,5	18	40
1	2,0	24	49
1	2,5	30	57
1	3,0	33	61
1	3,5	39	70
1	4,0	43	75
1	4,5	47	80
1	5,0	52	86
1	5,5	57	93
1	6,0	57	93
1	6,5	63	101
1	7,0	69	109
1	7,5	69	109
1	8,0	75	117
1	8,5	75	117
1	9,0	81	125
1	9,5	81	125
1	10,0	87	133
1	10,5	87	133
1	11,0	94	142
1	11,5	94	142
1	12,0	101	151
1	12,5	101	151
1	13,0	101	151

 25
  1
  4016707... 120367
  302 500 113

302 Metal case HSS DIN 338 ground, split point



	 D ø mm	 L2 mm	 L1 mm
10	1,0	12	34
10	1,5	18	40
10	2,0	24	49
10	2,5	30	57
10	3,0	33	61
10	3,5	39	70
10	4,0	43	75
10	4,5	47	80
10	5,0	52	86
10	5,5	57	93
10	6,0	57	93
10	6,5	63	101
10	7,0	69	109
10	7,5	69	109
10	8,0	75	117
5	8,5	75	117
5	9,0	81	125
5	9,5	81	125
5	10,0	87	133

 170
  1
  4016707... 122606
  302 800 170

HAMMER DRILL BITS

CHISELS

STONE AND
SPECIAL DRILL BITS

METAL DRILL BITS

WOOD DRILL BITS

SAWS









ASSORTMENTS

MODULES

METAL DRILL BITS









300 MultiPack HSS DIN 338, standard



		 D ø mm	 L2 mm	 L1 mm
1		4,0	43	75
1		5,0	52	86
1		6,0	57	93
1		8,0	75	117
1		10,0	87	133
5			 EAN 4016707...	 T12345
		10	904936	300 350 410









300 Plastic cassette HSS DIN 338, standard



		 D ø mm	 L2 mm	 L1 mm
1		1,5	18	40
1		2,0	24	49
1		2,5	30	57
1		3,0	33	61
1		3,2	36	65
1		3,5	39	70
1		4,0	43	75
1		4,5	47	80
1		4,8	52	86
1		5,0	52	86
1		5,5	57	93
1		6,0	57	93
1		6,5	63	101
13			 EAN 042492	 T12345
		10	042492	300 213 165

300 RoseBox HSS DIN 338, standard









		 D ø mm	 L2 mm	 L1 mm
1		1,0	12	34
1		1,5	18	40
1		2,0	24	49
1		2,5	30	57
1		3,0	33	61
1		3,5	39	70
1		4,0	43	75
1		4,5	47	80
1		5,0	52	86
1		5,5	57	93
1		6,0	57	93
1		6,5	63	101
1		7,0	69	109
1		7,5	69	109
1		8,0	75	117
1		8,5	75	117
1		9,0	81	125
1		9,5	81	125
1		10,0	87	133
19			 EAN 4016707...	 T12345
		1	042553	300 501 110

METAL DRILL BITS

300 RoseBox
HSS DIN 338, standard









	 D ø mm	 L2 mm	 L1 mm
1	1,0	12	34
1	1,5	18	40
1	2,0	24	49
1	2,5	30	57
1	3,0	33	61
1	3,5	39	70
1	4,0	43	75
1	4,5	47	80
1	5,0	52	86
1	5,5	57	93
1	6,0	57	93
1	6,5	63	101
1	7,0	69	109
1	7,5	69	109
1	8,0	75	117
1	8,5	75	117
1	9,0	81	125
1	9,5	81	125
1	10,0	87	133
1	10,5	87	133
1	11,0	94	142
1	11,5	94	142
1	12,0	101	151
1	12,5	101	151
1	13,0	101	151

 25
  1
  4016707... 042560
  12345 300 501 113

300 Metal box
HSS DIN 338, standard









	 D ø mm	 L2 mm	 L1 mm
1	1,0	12	34
1	1,5	18	40
1	2,0	24	49
1	2,5	30	57
1	3,0	33	61
1	3,5	39	70
1	4,0	43	75
1	4,5	47	80
1	5,0	52	86
1	5,5	57	93
1	6,0	57	93
1	6,5	63	101
1	7,0	69	109
1	7,5	69	109
1	8,0	75	117
1	8,5	75	117
1	9,0	81	125
1	9,5	81	125
1	10,0	87	133
1	10,5	87	133
1	11,0	94	142
1	11,5	94	142
1	12,0	101	151
1	12,5	101	151
1	13,0	101	151

 25
  1
  4016707... 042522
  12345 300 500 113

300 Metal box
HSS DIN 338, standard









	 D ø mm	 L2 mm	 L1 mm
1	1,0	12	34
1	1,5	18	40
1	2,0	24	49
1	2,5	30	57
1	3,0	33	61
1	3,5	39	70
1	4,0	43	75
1	4,5	47	80
1	5,0	52	86
1	5,5	57	93
1	6,0	57	93
1	6,5	63	101
1	7,0	69	109
1	7,5	69	109
1	8,0	75	117
1	8,5	75	117
1	9,0	81	125
1	9,5	81	125
1	10,0	87	133

 19
  1
  4016707... 042515
  12345 300 500 110

300 Metal case
HSS DIN 338, standard



	 D ø mm	 L2 mm	 L1 mm
10	1,0	12	34
10	1,5	18	40
10	2,0	24	49
10	2,5	30	57
10	3,0	33	61
10	3,5	39	70
10	4,0	43	75
10	4,5	47	80
10	5,0	52	86
10	5,5	57	93
10	6,0	57	93
10	6,5	63	101
10	7,0	69	109
10	7,5	69	109
10	8,0	75	117
5	8,5	75	117
5	9,0	81	125
5	9,5	81	125
5	10,0	87	133









 170
  1
  4016707... 042539
  12345 300 800 170

HAMMER DRILL BITS
CHISELS
STONE AND SPECIAL DRILL BITS
METAL DRILL BITS
WOOD DRILL BITS
SAWS
ASSORTMENTS
MODULES

METAL DRILL BITS









315 MultiPack
HSS bits drill KEILBIT, ground

		 D Ø mm	 L2 mm	 L1 mm
1		3,0	30	50
1		4,0	30	50
1		5,0	30	50
1		6,0	30	50
1		8,0	35	55
		 EAN 4016707-1	 12345	
5	10	105067	315 350 380	









317 Plastic cassette
HSS combination tool KEILBIT +
universal bit holder

		 D Ø mm	 L1 mm
1		2,5	36
1		3,3	39
1		4,2	41
1		5,0	44
1		6,8	50
1		8,5	59
		 EAN 4016707-1	 12345
7	1	150371	317 500 310









329 RoseBox
HSS countersink 90° KEILBIT + cutting
paste + bit holder

		 D Ø mm	 L1 mm
1		6,3	31
1		8,3	31
1		10,4	34
1		12,4	35
1		16,5	40
1		20,5	41
		 EAN 4016707-1	 12345
9	1	150449	329 500 620











327 RoseBox
HSS countersink 90° DIN 335 C

		 D Ø mm	 L1 mm
1		6,3	45
1		8,3	50
1		10,4	50
1		12,4	56
1		16,5	60
1		20,5	63
		 EAN 4016707-1	 12345
6	1	150210	327 500 620









325 RoseBox
HSS step drills

		 D Ø mm	 L1 mm
1		4,0 - 12,0	80
2		4,0 - 20,0	67
3		6,0 - 30,0	98
		 EAN 4016707-1	 12345
3	1	150050	325 500 103

METAL DRILL BITS







320 Keep case Hole saw bi-metal electrician's set I



			
			Ø mm
Hole saw bi-metal	1		22,0
Hole saw bi-metal	1		29,0
Hole saw bi-metal	1		35,0
Hole saw bi-metal	1		44,0
Hole saw bi-metal	1		51,0
Hole saw bi-metal	1		64,0
Locating shank AF 11 (14-30)	1		
Quick-rel.loc. shank AF 11 (32-152)	1		
			
8	1	110566	320 251 264







320 Keep case Hole saw bi-metal electrician's set II



			
			Ø mm
Hole saw bi-metal	1		35,0
Hole saw bi-metal	1		68,0
Hole saw bi-metal	1		83,0
Quick-rel.loc. shank AF 11 (32-152)	1		
			
4	1	110757	320 251 383



320 Keep case Hole saw bi-metal plumber's set



			
			Ø mm
Hole saw bi-metal	1		19,0
Hole saw bi-metal	1		22,0
Hole saw bi-metal	1		29,0
Hole saw bi-metal	1		38,0
Hole saw bi-metal	1		44,0
Hole saw bi-metal	1		57,0
Locating shank AF 11 (14-30)	1		
Quick-rel.loc. shank AF 11 (32-152)	1		
			
8	1	110559	320 251 957

320 Keep case Hole saw bi-metal fitter's set











			
			Ø mm
Hole saw bi-metal	1		22,0
Hole saw bi-metal	1		25,0
Hole saw bi-metal	1		29,0
Hole saw bi-metal	1		35,0
Hole saw bi-metal	1		44,0
Hole saw bi-metal	1		51,0
Hole saw bi-metal	1		57,0
Hole saw bi-metal	1		64,0
Hole saw bi-metal	1		68,0
Locating shank AF 11 (14-30)	1		
Quick-rel.loc. shank AF 11 (32-152)	1		
			
11	1	904967	320 252 268

WOOD DRILL BITS











180 MultiPack
Wood twist drill bit

		 D ø mm	 L2 mm	 L1 mm
1		4,0	43	75
1		5,0	52	86
1		6,0	57	93
1		8,0	70	117
1		10,0	87	120
		 EAN 4016707-1	 12345	
5	10	904974	180 350 410	



180 MultiPack
Wood twist drill bit

		 D ø mm	 L2 mm	 L1 mm
1		3,0	33	61
1		4,0	43	75
1		5,0	52	86
1		6,0	57	93
1		7,0	69	109
1		8,0	75	117
1		10,0	87	120
		 EAN 4016707-1	 12345	
7	10	904981	180 370 310	



300 | 190 | 180 Cassette
HSS - Stone - Wood

			 D ø mm	 L2 mm	 L1 mm
Masonry drill bit	1		5,0	52	86
Masonry drill bit	1		6,0	57	93
Masonry drill bit	1		8,0	75	117
Wood twist drill bit	1		5,0	50	85
Wood twist drill bit	1		6,0	60	100
Wood twist drill bit	1		8,0	80	120
HSS DIN 338	1		5,0	52	86
HSS DIN 338	1		6,0	57	93
HSS DIN 338	1		8,0	75	117
		 EAN 4016707-1	 12345		
9	9	905049	300 190 180		

MODULES



Hammer drill bit	158-159
Chisel	159
Percussion drill bit	160-162
Metal drill bit	163-164
Wood drill bit	165-166
Saws	166

HAMMER DRILL BITS

CHISELS

STONE AND
SPECIAL DRILL BITS

METAL DRILL BITS

WOOD DRILL BITS

SAWS

ASSORTMENTS

MODULES

MODULES

We equip your module the way you want it.



INDIVIDUAL COMBINATION

The modules can be combined flexibly. There are two ways to set up your personal drill bit centre. The standard module and the individual combinations - select the drilling tools you need.



PRODUCT GROUP LABEL

The product group label shows the drill bit type, its precise specification and the material in which it can be used. On the bottom side there is place for your information of rack maintenance like article numbers and EAN codes.



COLOUR GUIDANCE SYSTEM

Our colour guidance system guarantees fast orientation within the drill bit center. You are easily led to the products you look for.





DESIGNED FOR YOUR REQUIREMENTS

The perforated wall can be assembled with carefully composed modules or according to your individual demands. The usable area of the drill bit center is 175 x 100 x 47 cm. The height including head sign is 217 cm.



FLEXIBLE AND INDIVIDUAL

The modules can be combined flexibly. There are two ways to set up your personal drill bit centre:



ALTERNATIVE 1 FOR INDIVIDUAL EQUIPMENT

You decide - choose the drilling tools you need for your customers. Basically each drilling tool can be offered with self-service packing or on self-service hanger.

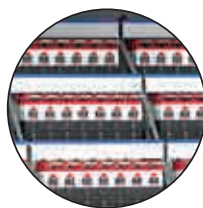

ALTERNATIVE 2 FOR STANDARD MODULES











Order proven combinations quickly and easily.

HAMMER DRILL BITS



251 Module shelve SDS-plus TURBOHEAD Xpro RS

[12-13]











	 D Ø mm	 L2 mm	 L1 mm	 EAN 4016707...	 12345
					
3	8,0	200	260	902130	251 080 260
3	10,0	200	260	902178	251 100 260
3	12,0	200	260	902239	251 120 260
3	12,0	400	450	902253	251 120 450
3	14,0	200	260	902284	251 140 260
3	14,0	400	450	902291	251 140 450
3	16,0	400	450	904738	251 160 450
					
5	8,0	150	210	902123	251 080 210
5	10,0	150	210	902161	251 100 210
5	12,0	100	160	902215	251 120 160
5	12,0	150	210	902222	251 120 210
5	14,0	100	160	902260	251 140 160
5	14,0	150	210	902277	251 140 210
5	16,0	150	210	904714	251 160 210
					
10	5,0	50	110	902000	251 050 110
10	5,0	100	160	902017	251 050 160
10	6,0	50	110	902031	251 060 110
10	6,0	100	160	902048	251 060 160
10	8,0	50	110	902109	251 080 110
10	8,0	100	160	902116	251 080 160
5	10,0	100	160	902154	251 100 160
				 12345	

121

251 800 121

253 Module shelve SDS-plus MS5 TURBOKEIL

[17-19]

	 D Ø mm	 L2 mm	 L1 mm	 EAN 4016707...	 12345
					
3	8,0	200	260	320927	253 080 260
3	10,0	200	260	320934	253 100 260
3	12,0	200	260	320958	253 120 265
3	12,0	400	450	320965	253 120 450
3	14,0	200	260	320972	253 140 265
3	14,0	400	450	320989	253 140 450
3	16,0	400	450	321009	253 160 450
					
5	8,0	150	210	322068	253 080 210
5	10,0	150	210	322082	253 100 210
5	12,0	100	160	322099	253 120 165
5	12,0	150	210	322105	253 120 215
5	14,0	100	160	322198	253 140 165
5	14,0	150	210	322204	253 140 215
5	16,0	150	210	322679	253 160 215
					
10	5,0	50	110	322006	253 050 110
10	5,0	100	160	322013	253 050 160
10	6,0	50	110	322020	253 060 110
10	6,0	100	160	322037	253 060 160
10	8,0	50	110	322044	253 080 110
10	8,0	100	160	322051	253 080 160
5	10,0	100	160	322075	253 100 160
				 12345	

121

253 800 121







HAMMER DRILL BITS | CHISELS



270 Module shelf

SDS-max W2 TURBOHEAD Xpro / TURBOKEIL X-shape

[23-24]

	 D ø mm	 L2 mm	 L1 mm	 EAN 4016707...	 12345
					
2	20,0	400	520	360107	270 200 521
2	22,0	400	520	360121	270 220 520
2	25,0	400	520	360152	270 250 520
1	30,0	450	570	360206	270 300 570
1	32,0	450	570	360220	270 320 570
1	35,0	450	570	360251	270 350 570
1	38,0	450	570	360275	270 380 570
					
2	12,0	200	340	360015	270 120 341
2	14,0	200	340	360039	270 140 341
2	16,0	200	340	360053	270 160 341
2	18,0	200	340	360077	270 180 341
2	20,0	200	320	360091	270 200 321
2	22,0	200	320	360114	270 220 320
2	24,0	200	320	360138	270 240 320

24

270 800 024

503 Module shelf

SDS-plus, SDS-max chisels

[42-44]

							 EAN 4016707...	 12345
SDS-max Point Chisel	3	400					260025	503 000 400
SDS-max Flat Chisel	3	400	25				260056	503 125 400
SDS-max Spade Chisel	3	300	80				260070	503 280 300
SDS-max Spade Chisel	3	400	50				260087	503 250 400
SDS-max Hollow Chisel	3	300	26				260094	503 326 300
SDS-max Channel with glide	3	380	35				260186	503 435 380
SDS-max Tile Chisel	3	300	50				260193	503 550 300
SDS-plus Tile Chisel	3	200	40				260162	502 540 200
SDS-plus Point Chisel	3	250					260117	502 000 250
SDS-plus Point Chisel	3	250					260100	502 000 251
SDS-plus Flat Chisel	3	250	20				260131	502 120 250
SDS-plus Spade Chisel	3	250	40				260148	502 240 250
SDS-plus Hollow Chisel	3	250	22				260155	502 322 250
SDS-plus Channel with glide	3	250	22				260179	502 422 250

42









503 800 042

STONE AND SPECIAL DRILL BITS



119 | 219 Module shelf
Universal drill bit GOLDCRAFT round shank / SDS-plus MS5

[48]









	 D Ø mm	 L2 mm	 L1 mm	 EAN 4016707...	 12345
					
3	6,0	100	160	213014	119 255 001
3	8,0	100	160	213021	119 255 002
3	8,0	150	210	213038	119 255 003
3	10,0	100	160	213045	119 255 004
3	10,0	200	260	213052	119 255 005
3	12,0	200	260	213076	119 255 007
3	14,0	200	265	213083	119 255 008
					
5	10,0	80	120	210105	119 000 100
5	12,0	90	150	210112	119 000 120
5	6,0	110	150	212024	219 000 060
10	8,0	135	200	212048	219 000 080
5	10,0	135	200	212055	219 000 100
5	12,0	135	200	212062	219 000 120
					
10	3,0	40	70	210013	119 000 030
10	4,0	40	75	210020	119 000 040
10	5,0	50	85	210037	119 000 050
20	6,0	60	100	210051	119 000 060
20	8,0	80	120	210082	119 000 080

126

119 800 126

151 | 258 | 130 Module shelf
Tile drill bit KERAMIK / Concrete drill bit MS5 TURBOKEIL / Glass drill bit

[52]

	 D Ø mm	 L2 mm	 L1 mm	 EAN 4016707...	 12345	
						
130	10	3,0	58	010019	130 000 030	
130	10	4,0	58	010026	130 000 040	
130	10	5,0	58	010033	130 000 050	
130	10	6,0	58	010040	130 000 060	
130	10	8,0	78	010064	130 000 080	
130	10	10,0	98	010088	130 000 100	
130	3	12,0	98	010095	130 000 120	
						
258	10	4,0	40	75	290015	258 000 040
258	10	5,0	50	85	290022	258 000 050
258	10	6,0	60	100	290039	258 000 060
258	10	7,0	60	100	290046	258 000 070
258	10	8,0	75	120	290053	258 000 080
258	10	10,0	75	120	290077	258 000 100
258	5	12,0	100	150	290084	258 000 120
						
151	10	4,0	40	75	510106	151 018 040
151	10	5,0	50	85	510113	151 018 050
151	10	6,0	60	100	510120	151 018 060
151	10	8,0	80	120	510137	151 018 080
151	10	10,0	80	120	510144	151 018 100
151	4				904868	151 350 410

182

151 801 182



STONE AND SPECIAL DRILL BITS



154 | 204 | 404 Module shelf

Granit drill bit PRIMUS

[6]

	 D ø mm	 L2 mm	 L1 mm	 EAN 4016707...	 12345
					
3	8,0	350	400	194016	404 000 080
3	10,0	350	400	194023	404 000 100
3	12,0	350	400	194030	404 000 120
3	14,0	350	400	194054	404 000 140
3	16,0	350	400	194061	404 000 160
3	18,0	350	400	194078	404 000 180
3	20,0	350	400	194085	404 000 200
					
5	10,0	80	120	190100	154 000 100
5	12,0	90	150	190117	154 000 120
5	14,0	90	150	190131	154 000 140
5	6,0	110	150	192012	204 000 060
5	8,0	135	200	192036	204 000 080
5	10,0	135	200	192043	204 000 100
5	12,0	135	200	192050	204 000 120
					
10	3,0	40	70	190018	154 000 030
10	4,0	40	75	190025	154 000 040
10	5,0	50	85	190032	154 000 050
20	6,0	60	100	190056	154 000 060
20	8,0	80	120	190087	154 000 080

126

154 800 126



150 | 200 | 400 Module shelf

Percussion drill bit KEILER

[62-63]

	 D ø mm	 L2 mm	 L1 mm	 EAN 4016707...	 12345
					
3	8,0	350	400	180033	400 000 080
3	10,0	350	400	180040	400 000 100
3	12,0	350	400	180057	400 000 120
3	14,0	350	400	180071	400 000 140
3	16,0	350	400	180088	400 000 160
3	18,0	350	400	180095	400 000 180
3	20,0	350	400	180101	400 000 200
					
5	12,0	90	150	200151	150 000 120
5	14,0	90	150	200175	150 000 140
5	6,0	110	150	203039	200 000 060
5	8,0	135	200	203060	200 000 080
5	10,0	135	200	203077	200 000 100
5	12,0	135	200	203084	200 000 120
5	14,0	135	200	203091	200 000 140
					
10	3,0	40	70	200014	150 000 030
10	4,0	40	75	200038	150 000 040
10	5,0	50	85	200052	150 000 050
20	6,0	60	100	200076	150 000 060
10	8,0	80	120	200106	150 000 080
10	10,0	80	120	200137	150 000 100

126

150 800 126







STONE AND SPECIAL DRILL BITS











190 | 290 | 400 Module shelf
Masonry drill bit OPAL / KEILER

[64]

	 D ø mm	 L2 mm	 L1 mm	 EAN 4016707...	 12345
					
3	8,0	350	400	180033	400 000 080
3	10,0	350	400	180040	400 000 100
3	12,0	350	400	180057	400 000 120
3	14,0	350	400	180071	400 000 140
3	16,0	350	400	180088	400 000 160
3	18,0	350	400	180095	400 000 180
3	20,0	350	400	180101	400 000 200
					
5	12,0	90	150	170119	190 000 120
5	14,0	90	150	170133	190 000 140
5	6,0	110	150	172014	290 000 060
5	8,0	135	200	172038	290 000 080
5	10,0	135	200	172045	290 000 100
5	12,0	135	200	172052	290 000 120
5	14,0	135	200	172069	290 000 140
					
10	3,0	40	70	170195	190 000 030
10	4,0	40	75	170010	190 000 040
10	5,0	50	85	170027	190 000 050
20	6,0	60	100	170041	190 000 060
10	8,0	80	120	170072	190 000 080
10	10,0	80	120	170096	190 000 100
					
				 12345	
126					190 800 126

710 | 711 | 713 | 715 Module shelf
Hollow core M16 with accessoires

[68-71]

	 D ø mm	 L2 mm	 L1 mm	 EAN 4016707...	 12345	
						
Hollow cores complete with SDS-plus holder and centre drill bit	2	68,0	52	72	160219	711 713 068
Hollow cores complete with SDS-plus holder and centre drill bit	2	80,0	60	80	160189	711 713 080
						
Universal hollow core 6-pieces item 715 incl. centre drill bit + locating plate	1				250019	715 033 073
Hollow cores M16	2	50,0	60	80	160073	710 000 050
Hollow cores M16	2	65,0	52	72	160103	711 000 065
Locating shanks SDS-plus	2			105	160301	713 080 120
Centre drill bits	2	8,0	72	120	916168	715 080 120
						
					 12345	
13						710 800 001











METAL DRILL BITS



307 Module shelf

HSS-E DIN 338 cobalt, ground, split point

[76-78]

	 D ø mm	 L2 mm	 L1 mm	 EAN 4016707...	 12345
					
10	6,5	63	101	063152	307 300 650
10	8,0	75	117	063190	307 300 800
10	8,5	75	117	063206	307 300 850
10	10,0	87	133	063237	307 301 000
5	12,0	101	151	063282	307 301 200
5	12,5	101	151	063299	307 301 250
5	13,0	101	151	063305	307 301 300
					
10	4,0	43	75	063084	307 300 400
10	4,2	43	75	063091	307 300 420
10	4,5	47	80	063107	307 300 450
10	4,8	52	86	063336	307 300 480
10	5,0	52	86	063114	307 300 500
10	6,0	57	93	063145	307 300 600
5	3,5	39	70	062995	307 320 350
					
5	1,0	12	34	062926	307 320 100
5	1,5	18	40	062933	307 320 150
5	2,0	24	49	062940	307 320 200
5	2,5	30	57	062957	307 320 250
5	3,0	33	61	062964	307 320 300
5	3,2	36	65	062971	307 320 320
5	3,3	36	65	062988	307 320 330
					
					











195

307 800 195

302 Module shelf

HSS DIN 338, ground, split point

[82-84]

	 D ø mm	 L2 mm	 L1 mm	 EAN 4016707...	 12345
					
10	6,5	63	101	120558	302 300 650
10	8,0	75	117	120596	302 300 800
10	8,5	75	117	120602	302 300 850
10	10,0	87	133	120633	302 301 000
5	12,0	101	151	120688	302 301 200
5	12,5	101	151	120695	302 301 250
5	13,0	101	151	120701	302 301 300
					
10	4,0	43	75	120459	302 300 400
10	4,2	43	75	120473	302 300 420
10	4,5	47	80	120480	302 300 450
10	4,8	52	86	120497	302 300 480
10	5,0	52	86	120503	302 300 500
10	6,0	57	93	120541	302 300 600
5	3,5	39	70	120749	302 320 350
					
5	1,0	12	34	122637	302 320 100
5	1,5	18	40	122644	302 320 150
5	2,0	24	49	122651	302 320 200
5	2,5	30	57	120718	302 320 250
5	3,0	33	61	120725	302 320 300
5	3,2	36	65	120732	302 320 320
5	3,3	36	65	122668	302 320 330
					
					

195

302 800 195

METAL DRILL BITS



300 Module shelf HSS DIN 338 standard

[86-88]

	D ø mm	L2 mm	L1 mm	EAN 4016707...	12345	
	10	6,5	63	101	043727	300 300 650
	10	8,0	75	117	043901	300 300 800
	10	8,5	75	117	043963	300 300 850
	10	10,0	87	133	044144	300 301 000
	5	12,0	101	151	044199	300 301 200
	5	12,5	101	151	044205	300 301 250
	5	13,0	101	151	044212	300 301 300
	10	4,0	43	75	043420	300 300 400
	10	4,2	43	75	043444	300 300 420
	10	4,5	47	80	043482	300 300 450
	10	4,8	52	86	043529	300 300 480
	10	5,0	52	86	043543	300 300 500
	10	6,0	57	93	043666	300 300 600
	5	3,5	39	70	044755	300 320 350
	5	1,0	12	34	044458	300 320 100
	5	1,5	18	40	044519	300 320 150
	5	2,0	24	49	044571	300 320 200
	5	2,5	30	57	044632	300 320 250
	5	3,0	33	61	044694	300 320 300
	5	3,2	36	65	044717	300 320 320
	5	3,3	36	65	044731	300 320 330

195

300 800 195



320 Module shelf Hole saw bi-metal and accessoires

[109-110]

	D ø mm	EAN 4016707...	12345	
Hole saw bi-metal	2	22,0	110078	320 000 022
Hole saw bi-metal	2	25,0	110092	320 000 025
Quick-rel.loc. shank SDS-plus (32-152)	1	110702	320 255 002	
Locating shank AF 11 (14-30)	1	110603	320 300 011	
Quick-rel.loc. shank SDS-plus (32-152)	1	110634	320 400 011	
Hole saw bi-metal	2	29,0	110115	320 000 029
Hole saw bi-metal	2	32,0	110139	320 000 032
Hole saw bi-metal	2	35,0	110153	320 000 035
Hole saw bi-metal	2	38,0	110177	320 000 038
Hole saw bi-metal	2	51,0	110245	320 000 051
Hole saw bi-metal	1	60,0	110290	320 000 060
Hole saw bi-metal	1	64,0	110306	320 000 064
Hole saw bi-metal	1	68,0	110337	320 000 068
Hole saw bi-metal	1	83,0	110382	320 000 083

21

320 800 024



WOOD DRILL BITS



181 | 180 | 183 **Module shelve**
Forstner / wood twist / auger drill bit

[121]

						
		ø mm	mm	mm	4016707...	12345
						
181	5	6,0	150	235	031403	181 060 250
181	5	8,0	150	235	031410	181 080 250
181	5	10,0	150	235	031427	181 100 250
181	5	12,0	380	460	031175	181 120 450
181	5	14,0	380	460	031182	181 140 450
181	5	16,0	380	460	031199	181 160 450
181	5	18,0	380	460	031205	181 180 450
						
180	10	3,0	33	61	020018	180 000 030
180	10	4,0	43	75	020025	180 000 040
180	10	5,0	52	86	020032	180 000 050
180	10	6,0	57	93	020049	180 000 060
180	10	8,0	75	117	020063	180 000 080
180	10	10,0	87	120	020087	180 000 100
180	10	12,0	96	151	020100	180 000 120
						
183	3	15,0		90	033223	183 000 150
183	3	20,0		90	033247	183 000 200
183	3	25,0		90	033278	183 000 250
183	3	26,0		90	033285	183 000 260
183	3	30,0		90	033308	183 000 300
183	3	35,0		90	033315	183 000 350
183	3	40,0		90	033322	183 000 400
						
						

126

183 800 126

180 | 181 | 350 **Module shelve**
Wood twist / auger / timbering drill bit

[121]

						
		ø mm	mm	mm	4016707...	12345
						
350	3	10,0	100	600	030215	350 100 600
350	3	12,0	100	600	030222	350 120 600
350	3	14,0	100	600	030239	350 140 600
350	3	16,0	100	600	030246	350 160 600
350	3	18,0	100	600	030253	350 180 600
350	3	20,0	100	600	030260	350 200 600
350	3	22,0	100	600	030277	350 220 600
						
181	5	12,0	380	460	031175	181 120 450
181	3	12,0	530	600	031298	181 120 600
181	5	14,0	380	460	031182	181 140 450
181	3	14,0	530	600	031304	181 140 600
181	5	16,0	380	460	031199	181 160 450
181	5	18,0	380	460	031205	181 180 450
181	3	18,0	530	600	031328	181 180 600
						
180	10	3,0	33	61	020018	180 000 030
180	10	4,0	43	75	020025	180 000 040
180	10	5,0	52	86	020032	180 000 050
180	10	6,0	57	93	020049	180 000 060
180	10	8,0	75	117	020063	180 000 080
180	10	10,0	87	120	020087	180 000 100
180	10	12,0	96	151	020100	180 000 120
						
						

120

180 800 120

WOOD DRILL BITS | SAWS



185 Module shelf Flat bit KEILBIT

[128]

Extensions	3		300	025198	185 000 001
		5	28,0 100 160	025136	185 280 160
		5	30,0 100 160	025143	185 300 160
		5	32,0 100 160	025150	185 320 160
		5	35,0 100 160	025167	185 350 160
		5	38,0 100 160	025174	185 380 160
		5	40,0 100 160	025181	185 400 160
		5	10,0 100 150	025037	185 100 150
		5	14,0 100 150	025068	185 140 150
		5	16,0 100 150	025075	185 160 150
		5	18,0 100 150	025082	185 180 150
		5	20,0 100 150	025099	185 200 150
		5	22,0 100 160	025105	185 220 160
		5	24,0 100 160	025112	185 240 160
		5	25,0 100 160	025129	185 250 160
		10	6,0 100 150	025013	185 060 150
		10	8,0 100 150	025020	185 080 150
		5	12,0 100 150	025044	185 120 150
		5	13,0 100 150	025051	185 130 150
		103			185 800 103

100 Module shelf Sharksaw

[135]

Replacement saw blade	3	530333	100 022 312	
Replacement saw blade	3	530050	100 022 410	
Replacement saw blade	3	530098	100 022 440	
Carpentry saw	3	530340	100 112 415	
Large Pruning saw	3	530142	100 105 424	
Carpentry saw	3	530326	100 112 312	
Fine cut saw	3	530043	100 112 410	
Fine cut saw with double edged blade	3	530081	100 112 440	
Replacement saw blade	3	530111	100 015 427	
MICRO pull saw	3	530296	100 100 554	
Pruning saw	3	530135	100 105 418	
Pruning saw	3	530104	100 105 427	

36		100 800 001

INFO



Point of Sale Systems	168-169
Contents	170-172
Quality Management	173
Website	174
Symbols	175

FOR IMPACTFUL PRODUCT PRESENTATIONS:

OUR POINT OF SALE SYSTEMS

KEIL PRESENTATION WALL

- Space productivity optimised shelf system with modules on 3 levels enables additional sales, as more products can be accommodated
- Shelving system can be designed flexibly
- Easy end-user orientation through colour coding system plus product information
- Compatible with Tego metal system
- **Total height:** 2,17 m
- **Width:** Available from 1 meter width; extensions in 1-meter steps (can easily be added)
- **Depth:** 47 cm



KEIL MINITOWER

- 4-sided rotating display
- Flexible assembly options
- Low space requirement
- High profitability per unit area
- **Optimal hanging surface:**
 - 17 cm x 60,5 cm
- **Total size:**
 - 19 cm x 70 cm



KEIL MAXITOWER

- 3-sided rotating display
- Flexible assembly options
- Low space requirement
- High profitability per unit area
- **Optimal hanging surface:**
 - 0,35 m x 1,5 m
- **Total size:**
 - 0,52 m x 1,8 m



CONTENTS

Description	Article group	Packaging	Page
Adapter M16 for SDS-plus	713 Hollow core		71
Adapters for SDS-plus	265 Adapter		36
Adapters with RATIO thread	259 Break-through core		34
Auger bit lewis shape	181 Wood drill bits		123
Auger bit lewis shape with SDS-plus	182 Wood drill bits		124
Break-through core drill bit type S with RATIO thread	259 Break-through core		31
Carpentry saw	100 Sharksaw		133
Centre drill bit for locating shank M16	715 Hollow core		71
Centre drill bit GOLDCRAFT for locating shank M16	719 Hollow core		67
Centre drill bit with RATIO thread	259 Break-through core		33
Chisel with channel and glides	500-509 Chisels		44
Chisels all fittings	500-509 Chisels		41-44
Chisels RS self-sharpening	500/501 Chisels		41
Combination set HSS - stone - wood	300 HSS drill bits	Assortments	154
Concrete drill bit MS5 TURBOHEAD Xpro	238 Stone- and special drill bits		59
Concrete drill bit MS5 TURBOKEIL	258 Stone- and special drill bits		60
Concrete drill bit MS5 TURBOKEIL	258 Stone- and special drill bits	Assortments	144
Cutting helix	259 Break-through core		32
Diamond core allround	774 Stone- and special drill bits		53
Drill bit for timbering, round shank	350 Wood drill bits		128
Drywall saw	100 Sharksaw		135
Extension for flat bit KeilBIT	185 Wood drill bits		127
Fine cut saw	100 Sharksaw		133
Fine cut saw with double edged blade	100 Sharksaw		134
Flat bit KeilBIT	185 Wood drill bits		126
Flat chisel	500-509 Chisels		42
Glass drill bit	130 Glass drill bit		56
Glass drill bit KeilBIT	131 Glass drill bit		57
Granite drill bit PRIMUS	154 Stone- and special drill bits		61
Granite drill bit PRIMUS	154 Stone- and special drill bits	Assortments	144
Hammer hollow core with RATIO thread	259 Break-through core		32-35
HARDTEC hard stone drill bit	168 Percussion drill bit		51
Hollow chisel	500-509 Chisels		43
Hollow core M16	710 Hollow core		69
Hollow core M16 assembly, SDS-plus	711 Hollow core		68
HSS bit drill KEILBIT, ground	315 HSS drill bits		101
HSS bit drill KEILBIT, ground	315 HSS drill bits	Assortments	152
HSS combination tool KeilBIT	317 HSS drill bits		102
HSS combination tool KeilBIT + universal bit holder	317 HSS drill bits	Assortments	152
HSS countersink 90° DIN 335 C	327 HSS drill bits		104
HSS countersink 90° DIN 335 C	327 HSS drill bits	Assortments	152
HSS countersink 90° KEILBIT	329 HSS drill bits		103
HSS countersink 90° KeilBIT + cutting paste + bit holder	329 HSS drill bits	Assortments	152
HSS deburring countersink 90° with cross hole	328 HSS drill bits		105

HSS deburring countersink 90° with cross hole	342 HSS drill bits		93
HSS DIN 1897 pilot drill bit, ground, split point, extra short	303 HSS drill bits		97
HSS DIN 338 ground, split point	302 HSS drill bits		82-84
HSS DIN 338 ground, split point	302 HSS drill bits	Self service pouch	85
HSS DIN 338 ground, split point	302 HSS drill bits	Assortments	148-149
HSS DIN 338 standard	300 HSS drill bits		86-89
HSS DIN 338 standard	300 HSS drill bits	Self service pouch	90
HSS DIN 338 standard	300 HSS drill bits	Assortments	150-151
HSS DIN 338 standard, shank reduced	300 HSS drill bits		91
HSS DIN 340 ground, split point, long	340 HSS drill bits		92
HSS DIN 345 morse taper	345 HSS drill bits		95-96
HSS DIN 8037 carbide tipped	310 HSS drill bits		98
HSS double-end drill bit, ground, split point	304 HSS drill bits		100
HSS Hole saw bi-metal	320 Hole saw		109-112
HSS Hole saw bi-metal electrician's set I	320 Hole saw	Assortments	153
HSS Hole saw bi-metal electrician's set II	320 Hole saw	Assortments	153
HSS Hole saw bi-metal fitter's set	320 Hole saw	Assortments	153
HSS Hole saw bi-metal plumber's set	320 Hole saw	Assortments	153
HSS hollow section drill bit / facade drill bit	344 HSS drill bits		94
HSS step drills	325 HSS drill bits		107
HSS step drills	325 HSS drill bits	Assortments	152
HSS TIN DIN 338 steel drill bit	238 stone- and special drill bits		80
HSS TIN DIN 338 steel drill bit	311 HSS drill bits	Self service pouch	81
HSS tube & sheet drill	326 HSS drill bits		106
HSS tube & sheet drill + cutting paste	326 HSS drill bits	Assortments	152
HSS wood twist drill bits	186 drill bits		121
HSS-E DIN 338 cobalt, ground, split point	307 HSS drill bits		76-78
HSS-E DIN 338 cobalt, ground, split point	307 HSS drill bits	Self service pouch	79
HSS-E DIN 338 cobalt, ground, split point	307 HSS drill bits	Assortments	145-146
HSS-G SPEEDER DIN 338 RN metal drill bit	312 HSS drill bits		99
Large pruning saw	100 Shanksaw		136
Locating shank M16 for SDS-plus TURBOKEIL complete	714 Hollow core		72
Locating shank M16 hexagon	712 Hollow core		70
Machine forstner drill bits, toothed	183 Wood drill bits		125
Masonry drill bit OPAL	190 Stone- and special drill bits		64
Masonry drill bit OPAL	190 Stone- and special drill bits	Assortments	144
Metal Display 375x235x205 mm, empty	384 HSS drill bits	Assortments	151
MICRO pull saw with metal blade	100 Shanksaw		135
NEO fine cut saw	100 Shanksaw		134
Percussion drill bit KEILER	150 Percussion- and special drill bits		62-63
Percussion drill bit KEILER	150 Percussion- and special drill bits	Assortments	144
Point chisel	500-509 Chisels		42
Pruning saw	100 Shanksaw		136
Quick bit holder for bits and KEILBIT	800 Various tools		72
Scriber	140 Various tools		108
SDS-max chisels	501/503 Chisels		41-44

Description	Article group	Packaging	Page
SDS-max concrete milling cutter	269 Hammer drill bits		29
SDS-max TURBOCLEAN extraction drill bit	273 Hammer drill bits		27
SDS-max W2 TURBOKEIL X-shape	270 Hammer drill bits		23-24
SDS-plus chisel	500/502 Chisels		41-44
SDS-plus drill bit for timbering	355 Wood drill bits		129
SDS-plus hammer drill bits KeilRAPID	256 Hammer drill bits		22
SDS-plus locating shank for bits and KEILBIT	264 Adapter		37
SDS-plus locating shank for chucks	264 Adapter		37
SDS-plus MS5 TURBOKEIL	253 Hammer drill bits		17-20
SDS-plus MS5 TURBOKEIL	253 Hammer drill bits	Assortments	142
SDS-plus MS5 universal drill bit GOLDCRAFT	119 Universal drill bits		50
SDS-plus Power-4CE	267 Hammer drill bits		14-15
SDS-plus TURBOCLEAN extraction drill bits	272 Hammer drill bits		28
SDS-plus TURBOHEAD Xpro RS	251 Hammer drill bits		12-13
SDS-plus TURBOHEAD Xpro RS	251 Hammer drill bits	Display	158
SDS-plus TURBOHEAD Xpro RS	251 Hammer drill bits	Assortments	139
SDS-plus W2 hammer drill bit X-shape	252 Hammer drill bits		16
Spade chisel	500-509 Chisels		43
Thread grease 120 grams, waterproof, heat resistant	259 Break-through core		33
Tile chisel	500-509 Chisels		44
Tile drill bit/KERAMIK diamond - dry drill	786 Tile/brick drill bits		54
Tile drill bit/KERAMIK diamond - dry drill	786 Tile/brick drill bits	Assortments	143
Tile/brick drill bit KERAMIK with TSM carbide tip	151 Tile/brick drill bits		52
Tile/brick drill bit KERAMIK with TSM carbide tip	151 Tile/brick drill bits	Assortments	143
Universal drill bit GOLDCRAFT	119 Universal drill bit		48
Universal drill bit GOLDCRAFT	119 Universal drill bit	Assortments	143
Universal drill bit KeilBIT	166 Universal drill bit		58
Universal drill bit KeilBIT	166 Universal drill bit	Assortments	144
Universal hollow core	715 Hollow core		65
Universal hollow core	715 Hollow core	Assortments	143
Universal hollow core M16 GOLDCRAFT	719 Hollow core		66
Wood twist drill bit	180 Wood drill bits		119
Wood twist drill bit	180 Wood drill bits	Assortments	154
Wood twist drill bit KeilBIT	187 Wood drill bits		122

QUALITY MANAGEMENT

KEIL DRILL BITS: FROM PROFESSIONALS FOR PROFESSIONALS – DEVELOPED FOR HIGHEST REQUIREMENTS AND TESTED UNDER EXTREME CONDITIONS!

All masonry- and concrete drill bits from Keil comply with highest requirements and go through extensive trials and test processes during their development. Your demand is our inducement only to bring first class products in the market and continuously improve our own standards. With the example of SDS-plus hammer drill bits our claim is established: Until the drill bits diameter is below the so called nominal diameter hit produced many drilling meters in C35/45 concrete.

Example: SDS-plus MS5 TURBOKEIL



Quality of concrete: C35/45
 Drill hammer: 2 KG hammer drill SDS-plus
 Trial: drilling on working length
 Mode of drilling: by hand or CNC-drill automat

Nominal-Ø (mm)	Drilling meters	Number of holes per 100 mm
5	7,5	75
6 - 7	10,0	100
8	15,0	150
> 8	20,0	200

Compensation due to complaints (nominal tool life)

If a complaint is justified will be detected by checking the wear of spiral or shank (measured at about 5 -15 mm below carbide). Is the complaint justified the drill bit will be replaced depending on its tool life.

KEIL DRILL BITS' BASICS:

The following are some tips how you can check by yourself before contacting Keil.



Checking manufacturers stamping

Keil drill bits carry the manufacturer's number 40. Please contact equivalent manufacturer with different number.



Deformed shank

When the shank is deformed the chuck of the drilling machine mostly has a defect which has to be repaired. No right for replacement of drill bit.



Carbide tip broken

A right of replacement is given when this claim occurs before going below nominal diameter. After reaching nominal diameter no right of replacement is given. Drill bit has reached its end of tool life.

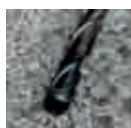

Carbide tip fell out

After the carbide tip fell out the drill bit was continuously used in stone or concrete. The drill bit will be replaced if the claim occurred before drill bit reached end of tool life. After that not replacement is possible.

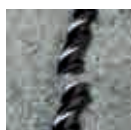

Fracture of spiral

When the complaint occurs before reaching the end of tool life, the drill bit will be replaced. After reaching nominal diameter, no replacement is possible.

www.keil.eu

On our website you will find all information about our products and services in several languages.

Find all data on our products, watch product videos, and find out about new products and actions! With our interactive and intuitive tools such as the "Product Finder" or the "Drive Finder" you can find the right tool for your application - all from one source!

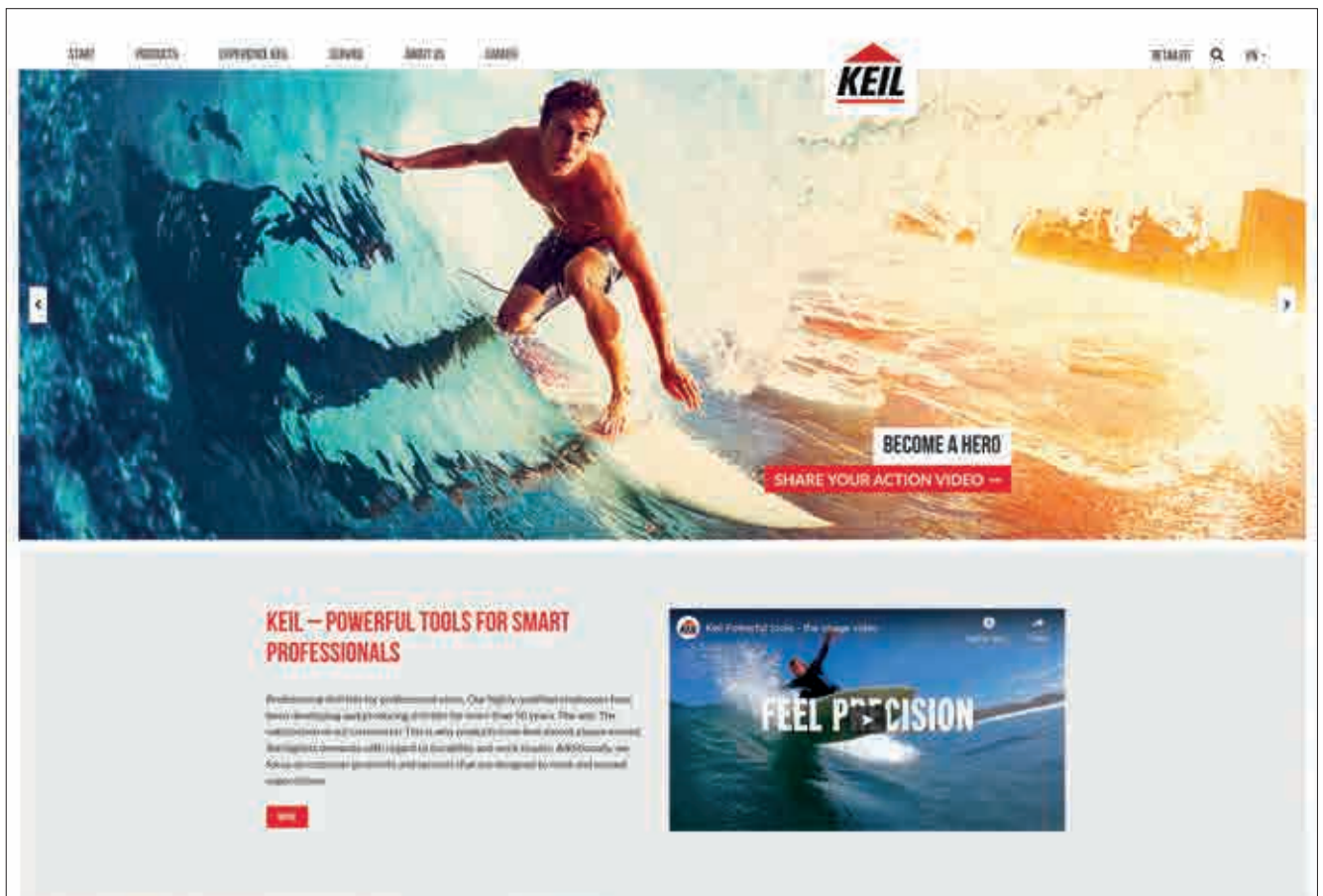

www.keil.eu

Terms and conditions: www.keil.eu/en/general-terms-and-conditions

CHART EXPLANATION

	Diameter mm
	Diameter Inch
	Working length
	Total length
	4-/2-cutter
	Shank diameter
	Hex shank length
	Spanner size
	Width
	Length of locating shank
	Metric thread
	Morse taper MK
	Working length saw (L2)
	Teeth/inch
	Suitable in / for / with
	Packaging unit
	Quantity units
	Content per item
	Rise
	Type
	Number / Size
	EAN
	Item number

DRIVE

	SDS-plus
	SDS-max
	Straight shank
	Hexagon
	Bit drive (C 6.3)
	Bit drive (E 6.3)
	ROTASTOP
	Morse taper
	Cone
	M 14

INFORMATION ABOUT PACKAGING

	Self-service pouch
	Self-service tube
	Hanger
	Twist tube
	QuadroPack / RectanglePack (content 1 piece)
	QuadroPack / RectanglePack
	Cardboard box
	Blister package
	Assortment
	Case
	Module
	Other packaging
	Module - Level 1
	Module - Level 2
	Module - Level 3

FOR USE IN

	Masonry
	Concrete / Reinforced concrete
	Natural stone
	Artificial stone
	Steel / Cast steel / various metal
	Stainless steel
	Wood
	Hardwood
	PVC / Acrylic
	Glass
	Ceramics
	Tiles / hard burnt brick

FURTHER INFORMATION

	TURBOHEAD Xpro
	TURBOKEIL centring tip 4-cutter
	TURBOKEIL centring tip 2-cutter
	TURBOCLEAN centring tip 3-cutter
	SDS-plus Power 4 CE 4-cutter
	Hammer drill bit tip 130° 2-cutter
	Carbide tipped
	The PGM-mark
	Not suitable for hammer action
	Max 1500 revolutions / min
	Diamond-tipped
	Wet drill
	Dry drill
	Page



Keil Profi-Werkzeuge

Tel: +49 (0) 4443 51444 - 0
E-mail: mail@keil.eu

www.keil.eu

